

**TANCO AUTORWAP
250 ARC MODEL 1996
OPERATORS HANDBOOK
AND
PARTS LIST
WD65-250-ARC-H0196**

GUARANTEE

Subject as hereunder provided, the Sellers undertake to correct either by repair or at their election by replacement any defect of material or workmanship which occurs in any of its goods within twelve months after delivery of such goods to first user, with the exception of contractors or commercial users when warranty period is six months.

In respect of Autowraps the warranty period is for 12 months or 8000 bales which ever occurs first.

In respect of Aerways tine breakage will be assessed on an individual basis in every case.

The term goods when used in this document means the article or articles described in invoice as sold by the sellers but does not include equipment or proprietary parts or accessories not manufactured by the sellers. The sellers, however, undertake to pass on so far as they legally can to the first user the benefit of any warranty given to the Sellers by the suppliers of such equipment, parts or accessories.

This understanding shall not apply to:

- (a) Any goods which have been sold by the first user.
- (b) Any goods which have been injured by unfair wear and tear, neglect or improper use.
- (c) Any goods the identification marks of which have been altered or removed.
- (d) Any goods which have not received the basic normal maintenance such as tightening of bolts, nuts, tines, hose connections and fittings and normal lubrication with the recommended lubricant.
- (e) The use of any product on tractors exceeding the recommended horsepower.
- (f) Any goods which have been altered or repaired other than on instruction or with the written approval of the Seller or to which any part not manufactured or having written approval by the Sellers have been fixed.
- (g) Any second-hand goods or part thereof.

Any allegedly defective part or parts returned to the Sellers must be sent carriage paid. ~~No claim for repair or replacement will be entertained unless~~ upon discovery of the alleged defect written notification is sent to the Sellers giving, at the same time, the name of the Buyer from whom the goods were purchased and the date of purchase together with full details of the alleged defect and the circumstances involved, also the serial number of the machine etc.,

The Sellers shall be under no liability to their Buyers and first and subsequent users of their goods or to any other person or persons for loss or damages howsoever arising in respect of either personal injuries or for arising out of, or in any way connected with or arising from the manufacturers sale, handling, repair, maintenance, replacement or use of its goods or the failure or malfunction of any of its goods.

Representation and/or warranties made by any person (including Buyers and employees and other representatives of the Seller) which are inconsistent or conflicting with these conditions are not binding upon the Sellers unless given in writing and signed by a Director of the Sellers.

CLAIMS

If you wish to make a claim under guarantee.

1. Immediately, stop using the machine.
2. List the details of the machine, its serial number and the part number of the damaged part.
3. Consult with your Tanco dealer (supplier) and have him forward your claim and the damaged item to Tanco.

INDEX**250 ARC MODEL****PAGE NO.**

GENERAL SAFETY INSTRUCTIONS	1/2/3/4/5
SPECIAL SAFETY SPECIFICATIONS	6
SAFETY DECALS	7
TECHNICAL SPECIFICATIONS	8
PRE DELIVERY INSTRUCTIONS	9/10/11
TRANSPORT INSTRUCTIONS	12
MACHINE IDENTIFICATION	12
PREPARATION OF A NEW MACHINE	13
HYDRAULIC CONNECTIONS	13
JUNCTION BOX AND CONTROLLER FOR 3 BANK VALVE	14
AUTOMATIC BALE WRAP CONTROLLER	15
OPERATOR ACCESSIBLE MONITOR PROGRAMMES	16/17/18
MODE OF OPERATION	19
OPERATING INSTRUCTIONS	20
REMOTE CONTROL FEATURES	21
FILM OVERLAP SYSTEM	22
SERVICE AND MAINTENANCE	23/24
FILM THREADING DIAGRAM	25
GEARBOX CHAIN DRIVE TENSIONING SYSTEM	26
TURNTABLE CHAIN DRIVE TENSIONING SYSTEM	27
FILM ADAPTOR OPERATING INSTRUCTIONS	28
ELECTRICAL COMPONENTS ILLUSTRATED	29
PARTS LIST FOR ABOVE	29:1
HYDRAULIC CIRCUIT DIAGRAM 250ARC MODEL (TRAILED)	30
HYDRAULIC COMPONENTS ILLUSTRATED 250ARC MODEL (TRAILED)	31
PARTS LIST FOR ABOVE	31:1
FITTING 2 WAY SOLENOID VALVE	32
CONSTANT INDEXING DRIVE ASSY ILLUSTRATED	33
PARTS LIST FOR ABOVE	33:1
AUTOWRAP ILLUSTRATED (250ARC MODEL)	34
PARTS LIST FOR ABOVE	34:1
TURNTABLE CHAIN DRIVE ASSEMBLY	35
PARTS LIST FOR ABOVE	35:1
SOLEMOID VALVE AND JUNCTION BOX ASSY (250ARC MODEL)	36
PARTS LIST FOR ABOVE	36:1
FILM DISPENSING SYSTEM ILLUSTRATED (250ARC MODEL)	37
PARTS LIST FOR ABOVE	37:1
FAULT FINDING SUMMARY	38
CUT AND START UNIT ILLUSTRATED	39
PARTS LIST FOR ABOVE	39:1
SLIP RING ASSY ILLUSTRATED	40
PARTS LIST FOR ABOVE	40:1
SENSOR MAGNET MOUNTING BRACKETS ILLUSTRATED	41
PARTS LIST FOR ABOVE	41:1
CUT AND START FAULT FINDING SUMARY	42

FIG 1 - PAGE No. 25

FIG 2 - PAGE No. 26

FIG 3 - PAGE No. 26

FIG 5 - PAGE No. 24

FIG 7 - PAGE No. 15

FIG 8 - PAGE No. 27

GENERAL SAFETY RECOMMENDATIONS

Before operating the machine, always ensure that the tractor and machine meet with work safety and road traffic regulations.

BASIC PRINCIPLES

- 1: In addition to the recommendations given in this manual, legislation on work safety and accident prevention must also be respected.
- 2: Advice is indicated on the machine, specifying safety recommendations in order to prevent accidents.
- 3: Before travelling on public roads, the operator must ensure that the machine conforms to road traffic regulations.
- 4: Before starting work, the operator must be familiar with all machine controls, handling devices and their functions. Once at work, it is too late to do this!
- 5: Do not wear loose clothing which could become caught up in moving elements.
- 6: The tractor should be equipped with a safety cab.
- 7: Before starting up the machine and beginning work, check the surrounding area (beware of children!). Make sure there is sufficient visibility. Keep all people and animals away from the danger zone of the machine (risk of projection!).
- 8: Carrying people or animals on the machine when working or in transport is strictly forbidden.
- 9: Machine must only be attached to tractor using means provided and in accordance with current safety standards.
- 10: Special care should be taken when attaching or removing the machine from the tractor.
- 11: Before transporting the machine on public roads, ensure that all legally required guards and indicators (lights, reflectors ...) are in place and in good operation.
- 12: All operating controls (cords, cables, rods etc.) must be positioned so that they cannot be set off accidentally, risking accident or damage.
- 13: Before travelling on public roads, put the machine into its transport position as instructed in this operators manual.
- 14: Never leave the tractor seat while the machine is operating.

- 15: Drive speed must be adapted to ground conditions as well as to roads and paths. Always avoid abrupt changes of direction.
- 16: Before operating the machine, ensure that all safety guards are firmly in place and in good condition. If worn or damaged, replace immediately.
- 17: Before operating the machine, check the tightness of all nuts and bolts, particularly on fixing elements (blades, tines, knives, spades etc.,).
- 18: Keep clear of the machine operating area.
- 19: **WARNING!** Danger of crushing and shearing can exist when components are operated by hydraulic or pneumatic controls.
- 20: Before leaving the tractor or before adjusting, maintaining or repairing the machine, turn off the engine, remove the ignition key and wait until all moving parts have come to a complete stop.
- 21: Do not stand between the tractor and the machine unless the hand brake is tight and/or stops have been placed under the wheels.
- 22: Before any adjustments, maintenance or repairs are carried out, ensure that the machine cannot be started up accidentally.

ADDITIONAL RECOMMENDATIONS FOR LINKAGE MOUNTED MACHINES

- 1: Before attaching the machine, ensure that the front tractor axle is sufficiently ballasted. Ballast is to be placed on the supports provided in accordance with instructions of the tractor manufacturer.
- 2: Do not exceed the maximum axle load or the overall transport weight prescribed by the tractor manufacturer.
- 3: Precision steering, tractor adherence, road holding and efficient braking are influenced by the type of implement, weight, ballast of front axle, ground or road conditions. It is therefore of utmost importance to be cautious in every given situation.
- 4: Be particularly cautious when turning corners, paying attention to machine overhang, length, height and weight.

SAFETY RECOMMENDATIONS FOR ATTACHING IMPLEMENTS TO TRACTOR

- 1: When attaching or removing the machine from the tractor, position hydraulic lift control lever in such a way that it cannot be set off accidentally.
- 2: When attaching the machine to the tractor hydraulic linkage, ensure that diameter of the link pins corresponds to the diameter of the ball joints.
- 3: **WARNING!** Danger of crushing and shearing can exist in the lifting zone of the tractor hydraulic linkage!
- 4: Do not stand between the tractor and the machine when operating the outer lever of the lift mechanism.
- 5: In transport, the machine lift mechanism should be stabilized by tractor tie rods to avoid floatation and side shifting.
- 6: When transporting the machine, lock the hydraulic lift control lever in place so that it cannot be lowered accidentally.

HYDRAULIC SYSTEM

- 1: **WARNING!** Hydraulic system is under pressure.
- 2: When fitting hydraulic motors or cylinders, ensure that connections have been made correctly, as per manufacturers instructions.
- 3: Before connecting hoses to the tractor hydraulics, ensure that tractor and machine circuits are not under pressure.
- 4: It is strongly recommended that the operator marks the hydraulic connections between tractor and machine to avoid making a wrong connection. **WARNING!** Functions could be reversed (for example: lift/lower).
- 5: Check hydraulic hoses regularly! Worn or damaged hoses must be replaced immediately. Replacement parts must be in accordance with the manufacturers recommendations concerning specifications and quality.
- 6: Should a leak be found, take all necessary precautions to avoid accidents.
- 7: Any liquid under pressure (particularly oil from hydraulics) can penetrate the skin and cause severe injury. If injured, see a doctor immediately, there could be a danger of infection.
- 8: Before any adjustments, maintenance or repairs are carried out, lower the machine, depressurize the circuit, turn off the engine and remove the ignition key.

MAINTENANCE

- 1: Before checking for any machine malfunction and before adjusting, maintaining or repairing the machine, turn off engine and remove ignition key.
- 2: Check tightness of nuts and bolts regularly. Retighten if necessary.
- 3: If the machine is raised, prop it up in a stable position before carrying out any maintenance work.
- 4: When replacing a working part, wear protection gloves and use only standardized tools.
- 5: It is forbidden to discard any oil, grease or filters. These must be given to waste disposal organisations to protect the environment.
- 6: Disconnect power source before any work is done to the electric system.

- 7: Check safety guards regularly, particularly those that are subject to wear. Replace immediately if damaged.
- 8: Spare parts used must be in accordance with specifications and standards as defined by the manufacturer. Use only genuine TANCO parts.
- 9: Before any electric welding is carried out on tractor or attached machine, disconnect generator and battery terminals.
- 10: Repairs on elements under pressure or tension (springs, accumulators etc.) must only be carried out by competent persons with standardized equipment.

OPERATING SAFETY INSTRUCTIONS

1. Operators should have their hands on the controls at all times when machine is in use.
2. Autowrap control unit and level controls must remain in the tractor cab at all times. The operator must at no time leave the tractor cab when the machine is in motion.
3. Keep onlookers clear of machine at all times. Danger zone is 5 metres.
4. Beware of rotating turntable and all moving parts.
5. If not operated correctly the bale could fly off the turntable. The end support rollers must always be fitted. Do not exceed recommended turntable speed of 30 r.p.m. Misshapen bales combined with excessive turntable speeds can be dangerous.
6. Care must be taken when tipping bales from machine on sloping ground and during subsequent handling to ensure that they do not roll, thus causing hazard.

THINK OF YOUR PERSONAL SAFETY AND THAT OF OTHERS AT ALL TIMES.

SAFETY DECALS

The following safety decals have been placed on your machine in the areas indicated. They are intended for your personal safety and for the safety of the people working with you. With this manual, walk around your machine and note the content and location of these warning signs. Review these decals and the operating instructions in the manual with your machine operators. Ensure that these decals are always legible. If they are not, replace them.

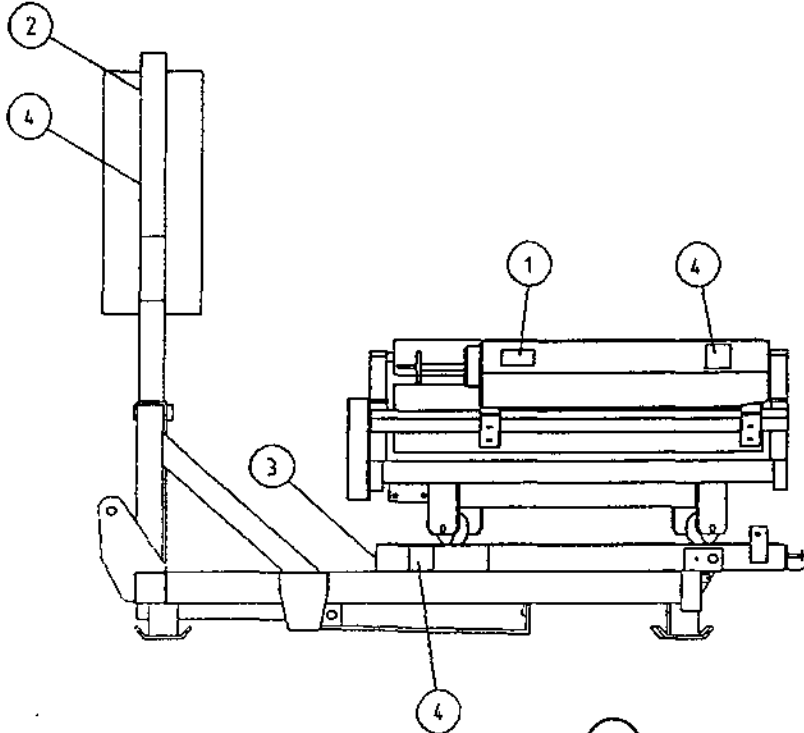

WARNING SHARP KNIFE

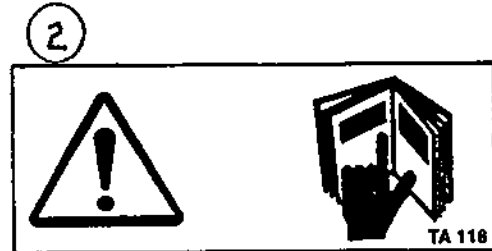

BEFORE STARTING THE MACHINE READ OPERATORS MANUAL AND SAFETY INSTRUCTIONS

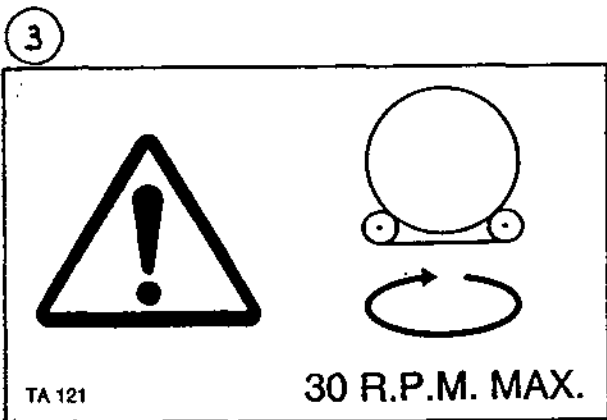

DO NOT EXCEED TURNTABLE SPEED OF 30 R.P.M



DANGER STAND CLEAR

TECHNICAL SPECIFICATIONS

250 ARC Model (3 point linkage)

Dimensions

Total length - Excluding Ramp	208 cm
Width with arm raised	157 cm
Height to top of side (bale guide) rollers	100 cm
Weight	650Kgs
Speed of turntable	30 rev/min
Oil Replacement	25 litres/min* (165 kp cm ²)
Attachment to tractor	Tractor Linkage
Bale Sizes	120 x 120 cm up to 120 x 153 cm max 1000 Kgs
Film (Width of Roll)	750mm

* The speed of rotation can be varied to suit various conditions but on no account should it exceed 30 r.p.m. (Speeds in excess of 30.p.m. will void warranty).

PRE DELIVERY INSTRUCTIONS

IMPORTANT: DO NOT ATTEMPT TO OPERATE UNTIL THE FOLLOWING INSTRUCTIONS ARE PERFORMED OTHERWISE SERIOUS DAMAGE COULD BE CAUSED.

1. MACHINE ASSEMBLY

For ease of transportation some items are removed from their positions and stored elsewhere on the machine. The control box, film dispenser and cut and start unit are stored under the bale belt. Also stored under belt on remote control machines are the infra red receiver and sender units and warning beacon. The film mast is attached to the front of the machine. On round bale machines only, the top rollers c/w mounting brackets and the plastic end rollers are mounted on temporary brackets beside the bale belt. Road wheels, bale lift arm and bale ramp are transported separately. Remove the above items and assemble as detailed in parts list section of this manual taking particular note of the following points.

(i) DISPENSER MAST

Insert lift mast into socket towards front of machine. Ensure film pull down ram is faced towards the machine. Attach the pull down arm hydraulic ram. Attach the film dispenser to the mast ensuring that the end marked top is faced up. On remote control machines attach the infra-red receiver and warning beacon to top of mast. The film mast is adjustable. Its position is dependant on bale size and type and is set in the field. It should be set so that centre line of film is in line with centre of bale. See Fig. 1

CUT & START

Attach Cut & Start unit to mounting frame on the left hand side of the machine. It is possible to move the unit along the mounting and fix it to any of three holes. On all round bale wrapping machines the unit is fixed to the centre hole on the mounting frame. Connect electrical supply to unit ensuring that wiring is secure. The cable is stored on the turntable frame near the Cut & Start mounting.

(iii) BALE LIFT ARM

Assemble bale lift arm and attach to mounting points on right hand side of main chassis. Attach hydraulic ram to lift arm; grease pivot pins.

(iv) TOP ROLLERS AND PLASTIC END ROLLERS

Place plastic end rollers in sockets on the back and front of the turntable. On round bale machines only, attach top rollers and mounting brackets to each side of the machine.

(v) ROAD WHEELS (trailed machines only)

Attach road wheels ensuring that nuts are tight and tyre pressure is 50 p.s.i.

(vi) BALE RAMP OR MAT

Attach bale ramp or mat to rear of chassis. Note Round bale trailed models have bale ramps with option hydraulic bale ramp. Linkage mounted machines have bale mats. A standard 1050 trailed models have hydraulic bale ramps.

SEE SEPERATE INSTRUCTION FOR FITTING HYDRAULIC BALE RAMP.

CHECKS TO BE PERFORMED

1. Check that all bolts and nuts are tight.
2. That all lubrication points are greased.
3. Check that all guards are in place.
4. Check all operating and safety stickers are in place.

2. OPERATIONAL TEST

When all above assembly and checks have been carried out the operation of the machine should be checked as follows:

NOTE: IF YOU ARE NOT TOTALLY FAMILIAR WITH THE OPERATION OF THE TANCO CONTROL SYSTEM READ THIS MANUAL IN FULL BEFORE PROCEEDING WITH OPERATIONAL TEST.

1. Attach machine to tractor.
2. Connect hydraulic hoses to D/A service on tractor.
3. Fit controller box inside cab.
4. Connect control box to machine and connect power cable direct to tractor battery. It is important that the leads are connected with the correct polarity. See Fig. 6.
5. Fit cable control actuator socket to convenient position in cab and locate actuators in socket.
6. Lock hydraulic lever in tractor so that oil is flowing through system.
7. Check function by operating control levers.
 - (a) Lift arm up and lift arm down. NOTE ensure lift arm is down before moving to (b).
 - (b) Turntable rotation forward and reverse.
 - (c) Tip up and down checking hoses are o.k.
8. Switch controller on.
9. Switch controller to manual operating mode by operating toggle switch.
10. Check Cut & Start plunger out and in.
11. Switch machine to AUTO mode then run through the Wrapping cycle. See operating instruction section of this manual on how the machine should perform, and if any function fails to operate correctly consult fault finding section of the operators manual.

3. CUSTOMER CHECKS

Before despatching consult customer on the following points:

1. That the machine model suits his requirements.
2. If machine is to be operated on a tractor with a closed centre hydraulic system then a closed centre valve is required, see separate instructions.
3. That the tow hitch type is compatible with the tractor. Three different hitch types are available.

TRANSPORT INSTRUCTIONS

1. Never use straps around the machine when lifting. Use only the following lifting points:- Tow hitch and two sockets on each side of main frame at rear for trailed models. 3pt. Linkage frame and two sockets on each side of main frame at rear for 3 pt. Linkage Model.
2. When the machine is towed on the road the Lifting Arm (if fitted) must be in the fully raised position, the safety prop fitted and the axle returned to narrowest position.
3. Raise the Parking Jack on trailed models before moving machine.

MACHINE IDENTIFICATION

The Serial Number plate is located on main frame forward of offside wheel on trailed models and on 3pt. Linkage frame for 3pt. Linkage model.

Always refer to this number when ordering parts. The Spare parts catalogue number and description should be used. The reference numbers are used to help identifying the spare part.

For your records write serial number here.

SERIAL NO. _____

PREPARATION OF A NEW MACHINE

1. Check height of film mast to ensure that centre line of film spool is level with the centre line of the bale on the turntable. This will alter with different bale diameters. If this alignment is not correct more film than necessary will be used. See Fig 1.
2. When connected to John Deere* tractor the valve must be converted to closed centre.

HYDRAULIC CONNECTIONS

Connect the feed and return hoses from the Autowrap valve to the tractor's double-acting facility.

NOTE: The return hose is fitted with a non-return valve to protect the Autowrap from damage in the event of incorrect connection to tractor hydraulics.

NOTE* To ensure maximum efficiency and length of life of hydraulic components this machine requires a clean supply of hydraulic oil. IT IS RECOMMENDED THAT THE TRACTOR HYDRAULIC FILTER ELEMENT BE REPLACED AND THEREAFTER MAINTAINED IN ACCORDANCE WITH THE MANUFACTURERS RECOMMENDATIONS.

TANCO AUTOWRAP 250 LRC MODEL (1996) JUNCTION BOX AND CONTROLLER FOR 2 BANK VALVE

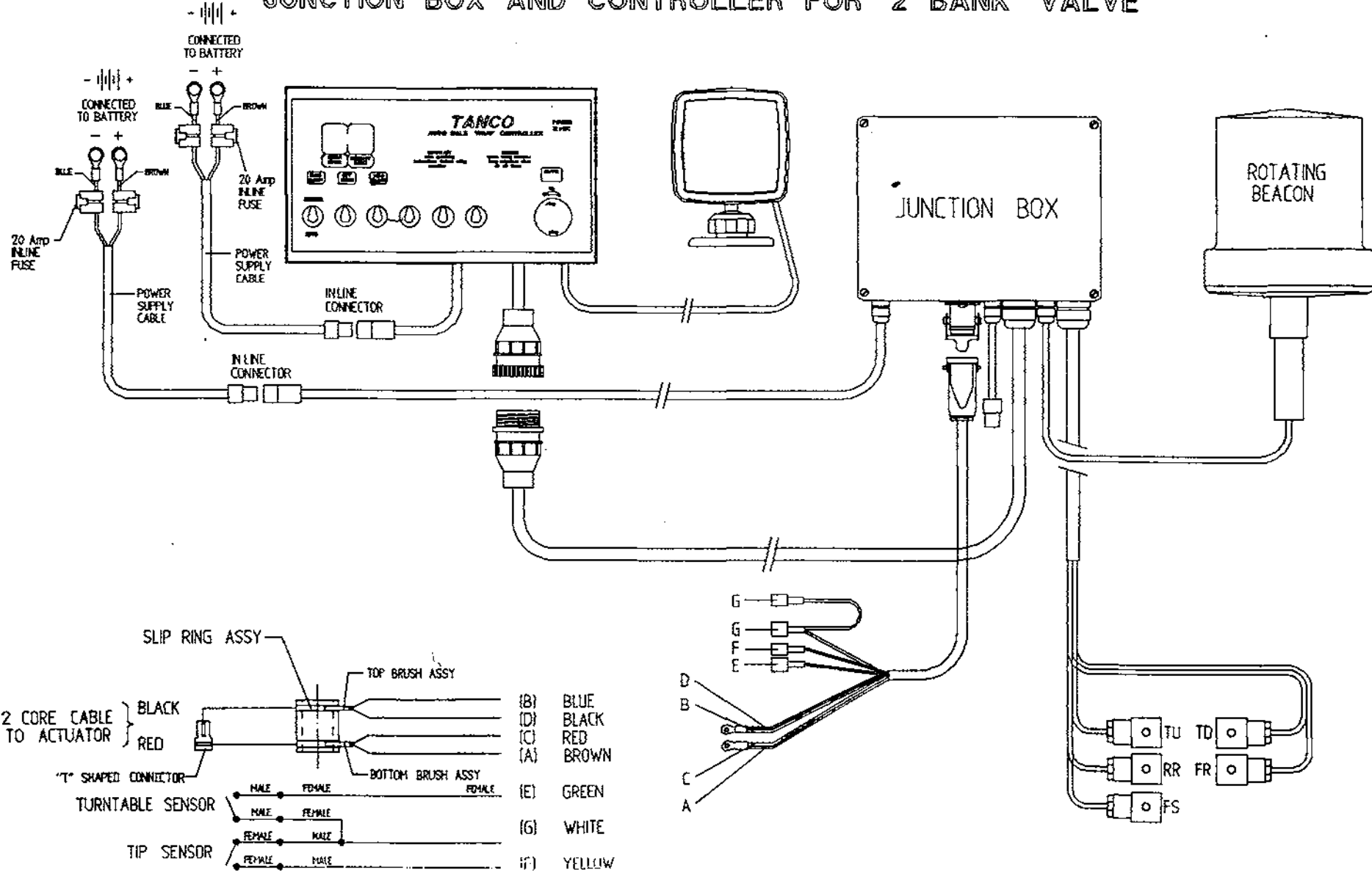

9227E

TANCO AUTOWRAP 250ARC MODEL 1996

ELECTRICAL COMPONENTS

PARTS LIST.

ITEM NO.	DESCRIPTION	QTY.	PART-NO.
1.	CONTROL BOX	1	D606
2.	JUNCTION BOX (2 BANK VALVE)	1	ZDG-JB2
3.	ROTATING BEACON	1	Z05-18
4.	STEM	1	Z05-181
5.	WARNER LINEAR ACTUATOR	1	ZD605-510
6.	RECEIVER	1	D6071
7.	INFRA RED REMOTE CONTROL TRANSMITTER	1	D6072
8.	SLIP RING ASSY.	1	ZD605-308
9.	BRUSHES	1	ZD605-302
10.	7 CORE CABLE C/W HEARTING PLUG	1	D605-7C
11.	24 CORE INTER CONNECTING LEAD C/W CONNECTORS	1	D605-24C
12.	SYSTEM PRESSURE LEAD	1	ZD606-070
13.	ROTATING SENSOR	1	ZD606-RS
14.	TIP SENSOR	1	ZD606-TS
15.	TWO CORE CABLE FOR SLIP RING	1	D605-02C
16.	MAIN BATTERY LEAD	2	ZD606-030
17.	IN-LINE FUSE	3	ZD606-100
18.	MAIN BATTERY LEAD FOR JUNCTION BOX	1	ZD606-040
19.	MAIN LEAD FOR JUNCTION BOX	1	ZD606-050
20.	ROTATING BEACON LEAD	1	ZD606-090
21.	LOOM FOR VALVE C/W HIRSCHMAN	1	ZD606-080

TANCO AUTOWRAP 200ARC MODELS (1996) ELECTRICAL COMPONENTS

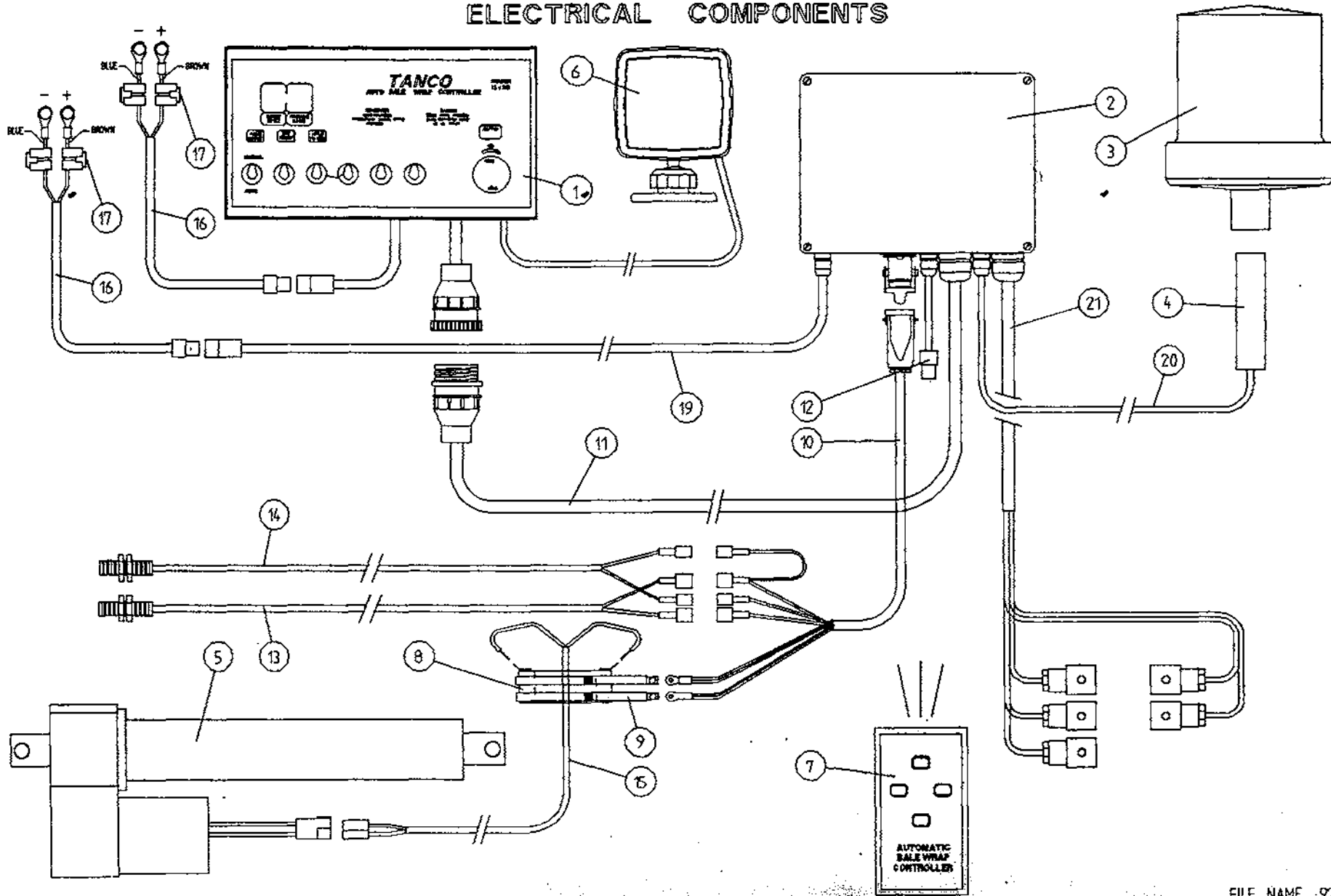

AUTOMATIC BALE WRAP CONTROLLER (issue 110 onwards)

The control unit on the 1996 Autowrap allows full automated control of the bale wrapping sequence. The control unit is pre-programmed to automatically wrap the bale to the required number of rotations. Once complete, the turntable stops in the correct position to allow the film to be cut and held. Incorporated is also an inching override facility on the control unit to move the turntable, left or right, to ensure that the film is properly gathered. Once the turntable is lowered it rotates automatically back through 90 degrees to facilitate loading the next bale. For reasons of safety loading and tipping off of the bale is operator controlled using switches on the control unit.

The programming of the Automatic Bale Wrap Controller is easily done by following the steps outlined below.

Once the unit is switched on, the number of required turntable rotations appears on the right hand display. To change this press and hold the "Hold to Set" button, see fig 7., then press the "Set/Reset" button. The first digit of the number will then blink and count from 0-9. Release the "Set/Reset" button at the required number. By pressing the "Set/Reset" again the second digit can be changed.

The monitor counts the number of bales per batch and the cumulative total. To see these, press the "bale count" button. The first number to appear is the batch total. If the button is held down for 10 seconds, a line will appear on the display, followed by the cumulative number wrapped. The batch count can be reset to 0 by holding the "Bale Count" button down and pressing the "Set/Reset" once. The cumulative total cannot be returned to zero.

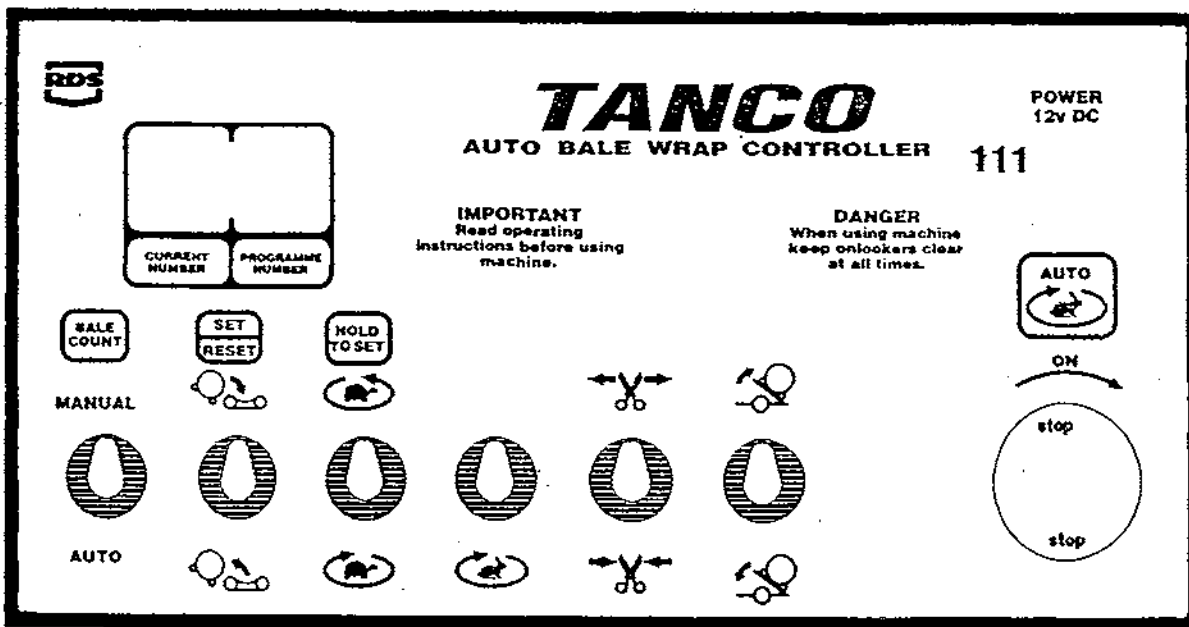

Fig. 7

OPERATOR ACCESSIBLE MONITOR PROGRAMMES

The Auto Bale Wrap Controller displays a total of 7 programmes. To access the programming mode, turn the power off by pressing the red button, then press and hold the 'hold to set' key and turn the power on, by rotating the red button. Now you have accessed to the programming mode. A chevron 'V' will appear in the left side of the left display - this indicates the first function. By pressing the 'hold to set' key the next programme is accessed and so on. The chevron 'V' will move across the display indicating each of the 7 functions. The functions and settings are as follows.

Programme 1: Park Position
Display Reading: 5.5 Seconds



Function: This is the time required for the 'Cut and Start' Actuator to return from the 'Open' position to the 'Park' position (See Diagram).

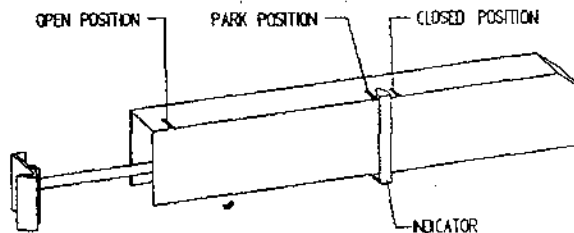

Due to varied output from tractor batteries, this reading may have to be altered to ensure that the indicator arm stops at the 'park' position.

- (i) If the indicator arm passes the 'park' position, then reduce the value by 0.1 sec. Repeat this until correct.
- (ii) If the indicator arm does not reach the 'park' position, then increase the value by 0.1 seconds until corrected.

Programme 2: Tip up.
Display reading: 4.0



Function: This controls the time for which the tipping ram extends out after the 'Cut and Start' closes. **Note:** This value requires to be altered only when the setting of the rear magnet that impulses the tip sensor is changed.

- (i) If the magnet is adjusted upwards then this value will have to be increased.
- (ii) If the magnet is adjusted downwards then this value is decreased. Adjustment is in 0.5 second increments.

Programme 3: Tip up to tip down delay
Display reading: 0.5



Function: Duration in seconds that the tipping ram remains fully extended between tip up and tip down.

Programme 4: Tip down.
Display reading: 4.8



Function: This controls the time required for the turntable to return to the horizontal position. **Note**: This value should be increased if the film pull down arm does not retract fully. Adjust in 0.1 increments.



Programme 5: Duration of slow rotation at end of wrapping cycle.
Display Reading: 1.2

Function: Shows time that elapses in seconds after turntable magnet passes rotate sensor on last rotation before turntable changes to slow mode. **Note**: This value need only be altered as follows.

- (i) To increase duration of slow rotation at end of wrapping cycle, reduce this value in 0.1 increments.
- (ii) To reduce duration of slow rotation at end of wrapping cycle, increase this value in 0.1 increments.

Programme 6: Machine Operation.

There are four separate settings for this programme depending on the model of machine being used. Two of the settings apply to remote control models and two to non remote models.

Remote control mode with no 90 degrees reverse function
= Symbol r.



Remote control mode with 90 degrees reverse function
= Symbol R.



Non remote control mode with no 90 degrees reverse
= Symbol o.

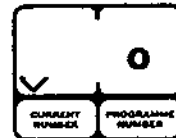

Non remote control mode with 90 degrees reverse
= Symbol O.

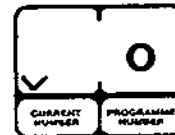

Programme 7: Tractor hydraulics.

Designed to convert the hydraulic system to open or closed centre hydraulics to suit tractor.

Closed centre = Symbol J

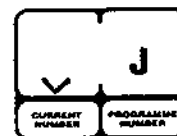

Open centre = Symbol n.

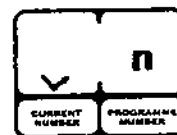

NOTE: An additional valve is required for operating in the J mode.

MODE OF OPERATION

Automatic Mode: with switch in "Auto" Position.

1. Ensure turntable is in correct position to accept bale and that film is gripped by the "Cut and Start".
2. Lower bale lift arm, drive alongside, pick up the bale and raise the lift arm.
3. Allow the bale to roll gently onto the turntable so that it is central between the end rollers.
4. Lower the arm clear of the turntable and press the "Auto" (Start) button commence wrapping. NOTE: The table must be in the correct position before the "Auto" (Start) button is pressed. If not the table may stop in the wrong position at the end of wrapping.
5. With the controller in Automatic Mode the turntable will start off for half of one rotation in "Slow Mode" before changing to "Fast Mode". During the final rotation it will change to "Slow Mode" and stop in the correct position so that the film is lined up above the open "Cut and Start".
NOTE: The turntable can be moved to left or right to align the "Cut and Start" by using the slow rotate switch on the controller or the buttons on the remote control unit.
6. On the third rotation of the wrap cycle the "Cut and Start" will open automatically. An indicator on the outside panel shows what stage the "Cut and Start" is at. On the ninth revolution the actuator will return to the "Park Position" indicating that the "Cut and Start" is ready to close. Note: The indicator must be at the "Park Position" in either Manual or Automatic Mode before the "Cut and Start" will close.
7. When in a safe position to do so, press the "Tip Up" button, the turntable will tip upwards gathering the film on the "Cut and Start" plunger whilst the pull down arm reduces the film to a rope which is cut as the "Cut and Start" snaps shut, releasing the bale but gripping the film end in readiness for the next bale.
8. The tip off sequence is automatic and once the turntable lowers it will reverse and stop in position to facilitate loading, if programmed to do so.

Manual Mode: with switch in "Manual" Position

1. Load the bale as outlined above.
2. Using the slow rotation switch, start the wrapping cycle.
3. After half of a rotation, switch to the fast wrapping mode by pressing the appropriate switch.
4. During the wrapping extend the "Cut and Start" out to the end mark and return the indicator to the "Park Position".
5. At the end of the wrap cycle line up the "Cut and Start" with the film.
6. When safe to do so, tip up the turntable until all the film is gathered on the "Cut and Start". Operate switch to close position, the "Cut and Start" will snap shut cutting the film. Continue tipping until the bale rolls off then lower the turntable.
7. Position the turntable to load the next bale.

OPERATING INSTRUCTIONS

250 ARC MODEL

1. Fit roll of film and thread through the Dispenser roller assembly by following the instruction label on the film mast.
2. Adjust tractor engine speed to give turntable speed of 16 - 30 r.p.m., NOTE: Speeds in excess of 30 r.p.m. will void Warranty.
3. Lower bale into position with a Grab. Attach film tag to gripper section of cut and start unit.
4. Start wrapping. Film tension is automatically set so that width of film applied to the bale stays at a constant width of 405-410m for 500mm film and 615mm for 750mm film.
5. Continue wrapping until the automatic wrap cycle is completed, at which stage the turntable will stop with cut and start facing towards front of machine.
6. Tip bale from machine. When the machine is almost fully tipped the cut and start unit grips and cuts the film and the bale is then unloaded onto the bale mat.
7. Lower the turntable.
8. Repeat operations 3 - 7 as required.

NOTE: The film end need only be attached at the start of a roll, after that the sequence is automatic.

REMOTE CONTROL FEATURES OF THE AUTOWRAP 250 ARC

- * Designed to wrap at the stack, the 250 ARC is controlled entirely from the cab of the loader tractor. The machine's features include:-
- * Infra Red Remote Controlled Wrapping Sequence.
 1. Programme the wrapper for the number of revolutions required. NB. The total number of bales wrapped is also recorded.
 2. Load the bale onto the wrapper and as you reverse out activate the wrapping cycle using the infra-red remote controller. When the cycle is completed the turntable will stop automatically in the tip position.
 3. Whilst the first bale is being wrapped gather another bale and approach the wrapper. Using the remote controller tip off the wrapped bale. The film is automatically cut by the cut and start and the table returned to the load position.
 4. Load the next bale and activate the wrapping cycle again. Whilst this bale is being wrapped, stack the newly wrapped bale. Repeat the procedure.

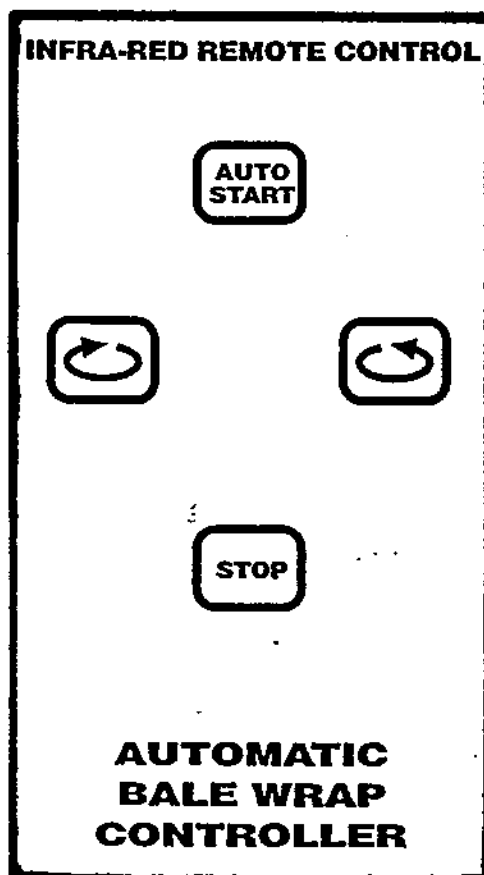

FILM OVERLAP SYSTEM.

The Autowrap is fitted as standard with the 2 x 2 x 50% film overlap system. This is achieved by means of a chain drive which ensures that the correct number of film layers are applied to the bale after a specific number of revolutions of the turntable. The number of revolutions required to wrap a bale depends on width of film being used and bale size - See Table 1 below. The chain to be positioned on inner sprockets for 750mm wide film and on outer sprockets for 500mm wide film. See fig. A below.

For silage bales we recommend the application of a minimum of four layers of film.

Table 1

Bale Size	Width of Film Roll	Bale Indicator Setting (Revs)
120cm x 120cm	500mm	25
120cm x 120cm	750mm	17
120CM x 137cm	500mm	28
120CM x 137cm	750mm	19
120CM x 150cm	500mm	31
120CM x 150cm	750mm	21

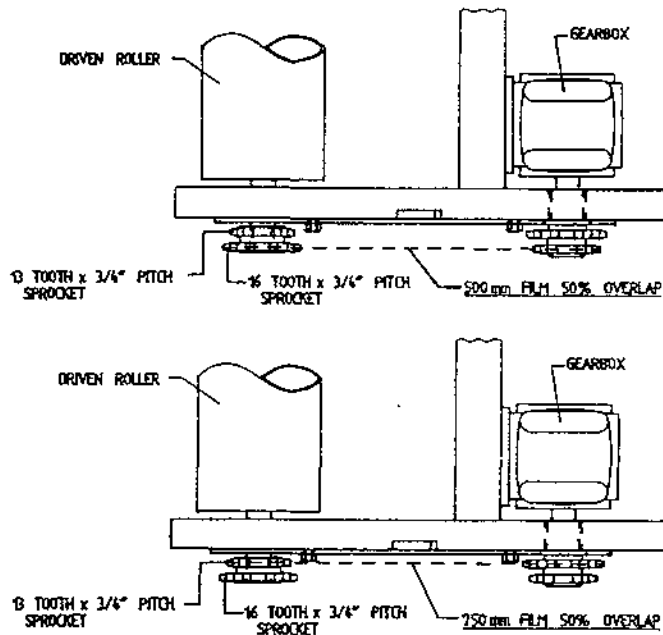

FIG. A

IMPORTANT

The above recommendations are only offered as a guide to correct wrapping of silage bales and the manufacturer accepts no responsibility for variations that may arise and the consequence of same. They are based upon turntable speeds of up to 25 r.p.m., and an approx film width of 400mm applied to end of Bale when using 500mm wide film roll or an approx film width of 600mm applied to end bale when using 750mm wide film roll.

It is the responsibility of the operator to ensure the correct number of wraps are applied, as variances can occur with fluctuations in speed of rotation, film quality and tensioning, shape and density of bale etc.

SERVICE AND MAINTENANCE.

- 1: All nuts and bolts should be tightened after one hour in use and thereafter regularly.
- 2: Wheel pressure should be normally kept at 42 psi depending on bale weight and field conditions.
- 3: Inspect moving parts for wear on daily basis.
- 4: Lubrication.

Drive chain & sprocket	-	Grease every 24 hours.
Main rollers	-	Grease every 24 hours.
Hinge pins on Lift Arm	-	Grease every 24 hours.
Hinge pins on main tip frame	-	Grease every 24 hours.
Hydraulic rams	-	Grease every 24 hours.
Film spool assy.	-	Grease every 24 hours.
Dispenser gearboxes	-	Grease sparingly each month. See 6.
Main spindle	-	Grease every 4000-5000 bales.
- 5: Adjustments.

Turntable Drive chain:	Adjust after first days work then check/adjust every 50 hours. See Fig. 8.
Gearbox Drive chain:	Adjust after first days work then check/adjust every 50 hours. See Fig. 2.
Roller Drive chain:	Adjust after first days work then check/adjust every 50 hours. See Fig. 3.
Main Bale Belt:	See belt tracking instructions.
- 6: Film Dispenser.

Fit with marked gearbox at top.
Apply one shot of EPO type grease. Failure to use this grease will nulify 2 year warranty on this part.
Wash rollers often to avoid build up of Tack from film using petrol.
Follow film threading diagram. See Fig. 1.
- 7: Film Adjustment.

Centre of film roll must be in line with centre of bale and film mast should be vertical.

8. Shear Pins

There are two shear pins fitted to sprocket assembly on drive roller see fig 5. If the pins shear, remove the broken pins re-align holes and fit two replacement spiral pins, 6mm dia x 20mm long, Din 7343. There are two spare shear pins attached to inside of chain guard.

NOTE: If shear pins are replaced with other than specified above all warranty is null and void.

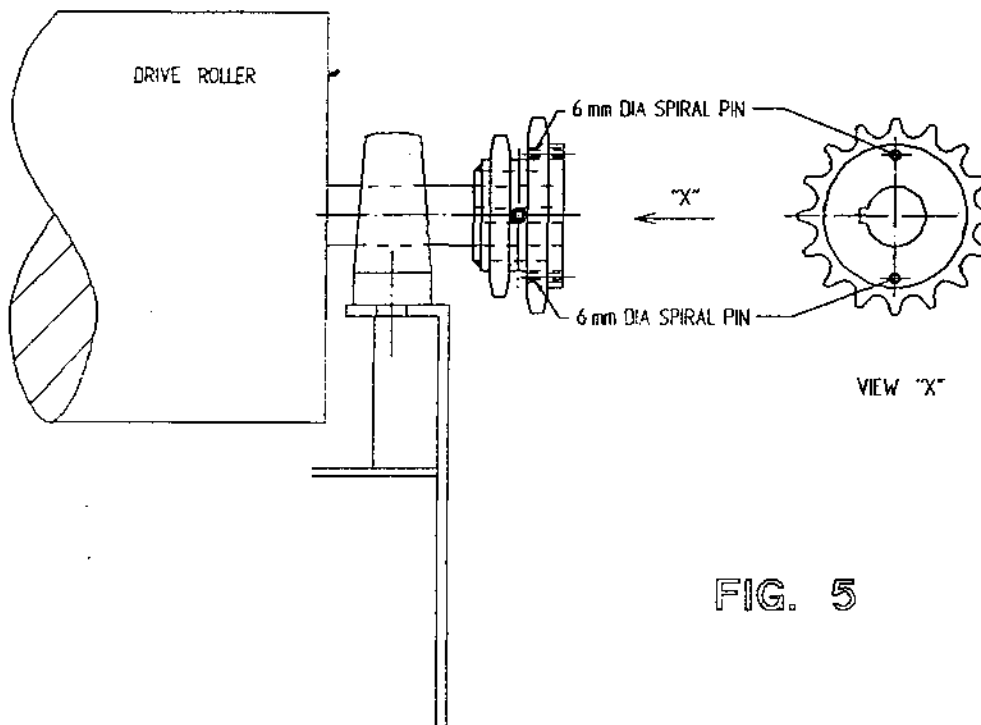
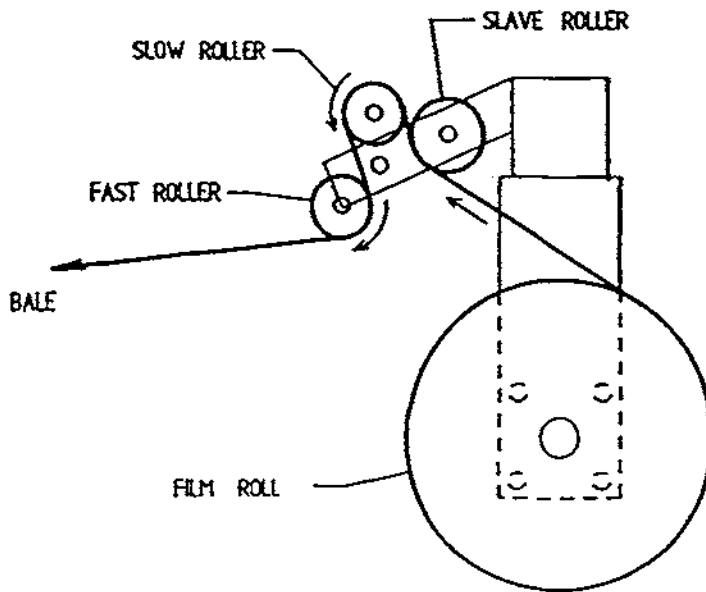

FIG. 5

SERVICE AND MAINTENANCE (CNT.) HYDRAULIC FILTER

1. Before connecting Autowrap to tractor, change oil in tractor hydraulic system and replace hydraulic filter.
2. After 25 hours max. it will be necessary to replace the element in Autowrap filter.
3. For maintenance purposes it is necessary to change the element after 200 working hours.
4. The element cannot be just cleaned and put back into the filter.

TANCO AUTOWRAP FILM THREADING DIAGRAM



FILM ADJUSTMENT

CENTRE OF FILM ROLL MUST BE IN LINE WITH CENTRE OF BALE AND FILM MAST SHOULD BE VERTICAL.

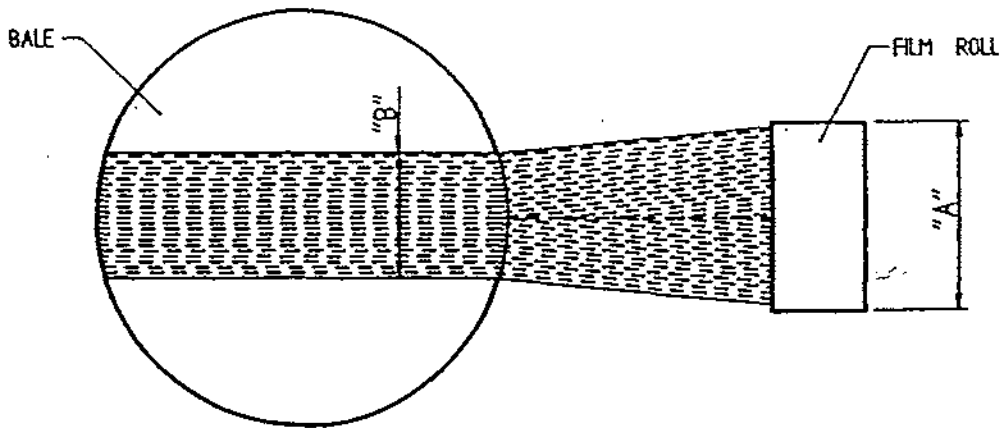

FILM ROLL WIDTH "A"	FILM WIDTH ON END OF BALE "B"
500 mm	400 mm
750 mm	600 mm

Fig. 1

FILE NAME W058-LA21

TANCO AUTOWRAP CONSTANT INDEXING
GEARBOX CHAIN DRIVE TENSIONING SYSTEM (1996)

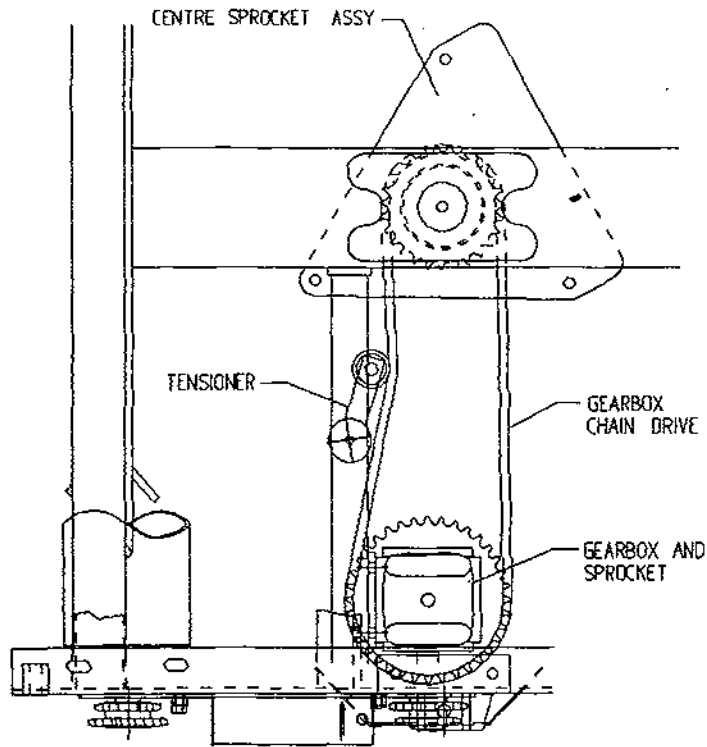

CHAIN TENSIONING PROCEDURE

1. LOOSEN M10 BOLT SECURING CHAIN TENSIONER.
2. TENSION CHAIN BY ADJUSTING TENSIONER USING SPANNER IN DIRECTION OF ARROW "X" UNTIL SETTING OF 15"-20" IS REACHED.
3. RE-TIGHTEN M10 BOLT TO SECURE TENSIONER IN POSITION.

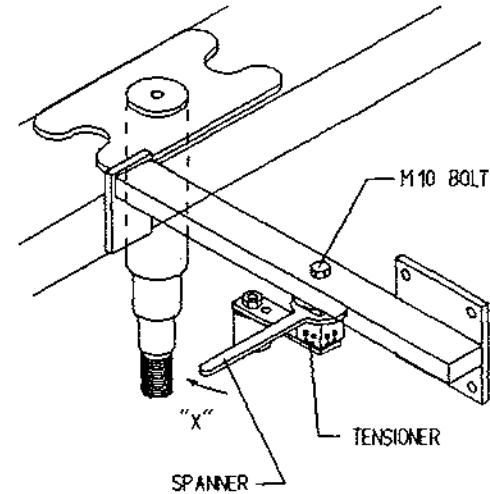
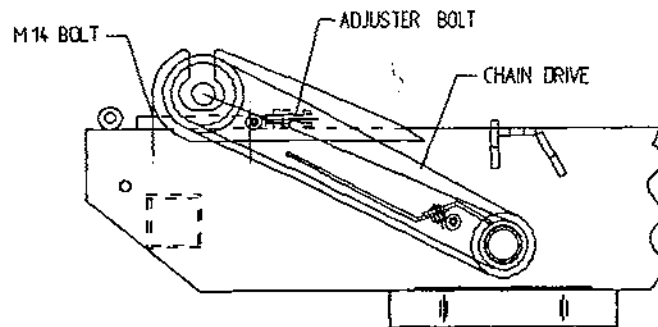

Fig. 2



ROLLER CHAIN DRIVE TENSIONING SYSTEM

CHAIN TENSIONING PROCEDURE

1. LOOSEN M14 BOLTS SECURING BEARING.
2. TENSION CHAIN BY LOOSENING LOCKING NUT AND TURNING ADJUSTER BOLT CLOCKWISE TO TAKE UP SLACK IN CHAIN. SECURE IN POSITION WITH LOCKING NUT. ENSURE EQUAL ADJUSTMENTS ARE MADE ON BOTH SIDES.
3. RE-TIGHTEN M14 BOLTS SECURING BEARINGS TO 170 Nm. (125 FT. lbs.).

Fig. 3

TANCO AUTOWRAP 1996 MODEL TURNTABLE CHAIN DRIVE TENSIONING SYSTEM

TENSIONING PROCEDURE

1. TIP UP MACHINE AND SUPPORT WITH A PROP.
2. REMOVE CHAIN GUARD.
3. SLACKEN M12 CLAMPING BOLTS SLIGHTLY.
4. SLACKEN LOCKNUT A.
5. ADJUST NUT B UNTIL THERE IS 8mm-10mm DEFLECTION ON CHAIN.

NOTE WARNING:
DO NOT OVER TENSION CHAIN AS MOTOR WILL BE DAMAGED

6. TIGHTEN LOCKNUT A.
7. TIGHTEN M12 CLAMPING BOLTS.
8. REFIT CHAIN GUARD.

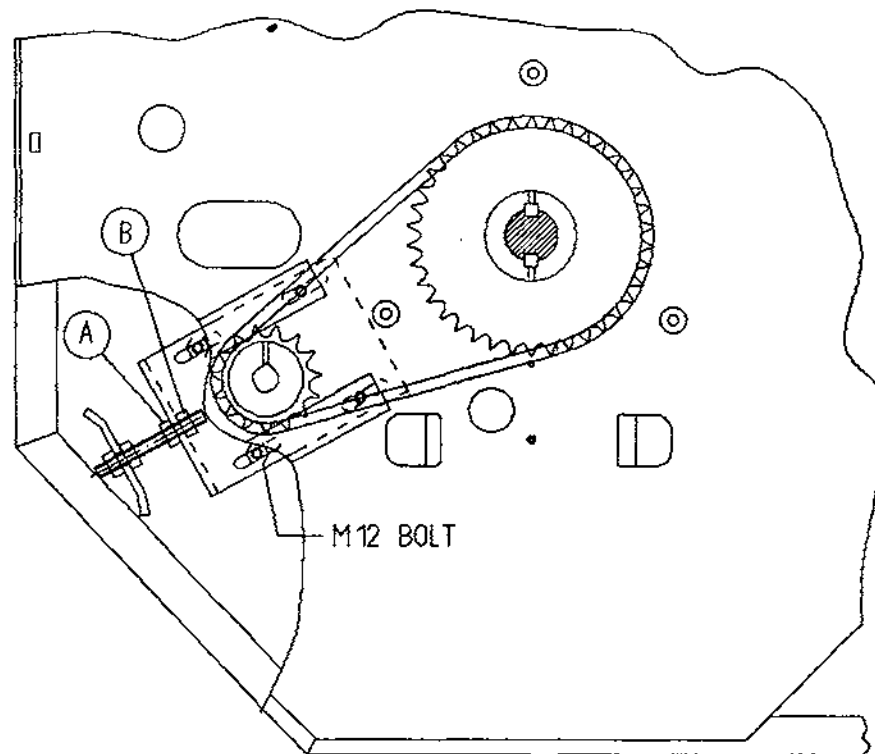

Fig. 8

FILE NAME WD64-LA2

FILM ADAPTOR

OPERATING INSTRUCTION

500mm wide film rolls are used as standard on 250, 350, & 450 Autowrap Models while 750mm wide film rolls are used as standard on 550 model. If however, it is found necessary to use 500mm wide rolls along with 750mm film dispenser the following instructions must be adhered to: (NOTE: Failure to do so will result in inadequate wrapping and bale spoilage).

1. Fit film adaptor to top end of 500mm wide film roll as shown opposite.
2. Remove drive chain from inner set of sprockets and fit to outer set of sprockets as shown in Fig. below.
3. Re-tension chain.
4. Adjust height of film mast so that centre of film roll is in line with centre of bale on the turntable.
5. Adjust bale wrap indicator setting from 17 to 25 revolutions for 120cm x 120cm blaes. (See Table 1 for guide to bale wrap indicator settings).

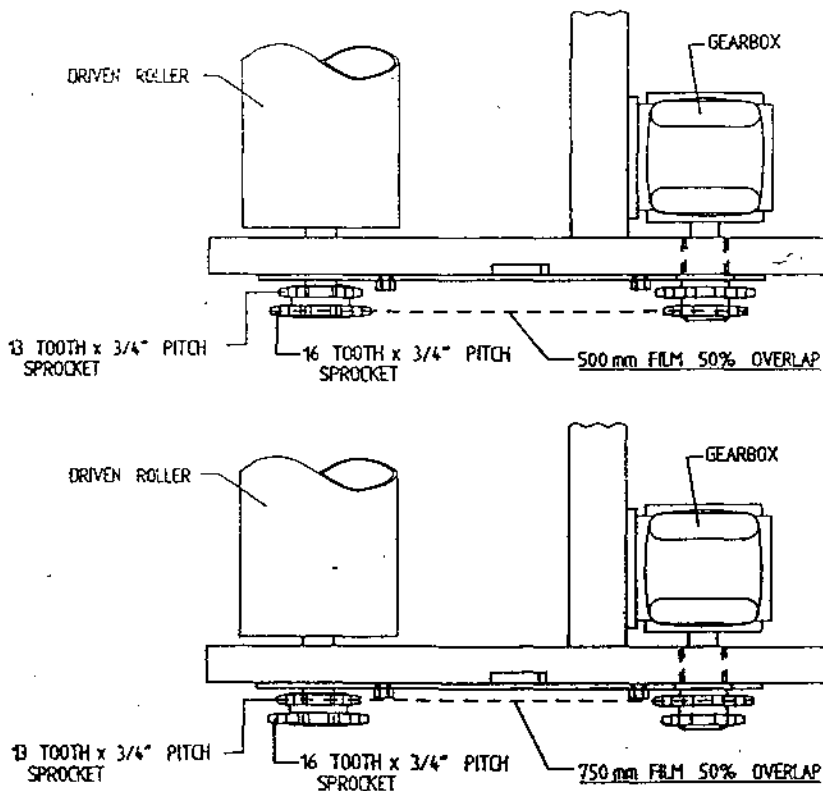
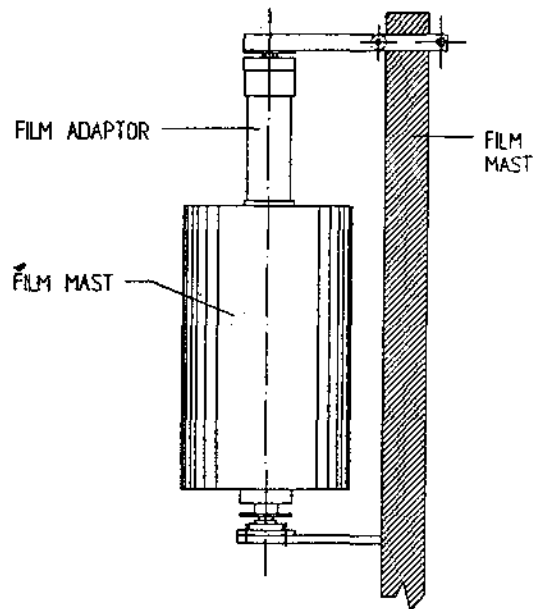

TANCO AUTOWRAP 250 ARC MODEL 1996 HYDRAULIC CIRCUIT DIAGRAM

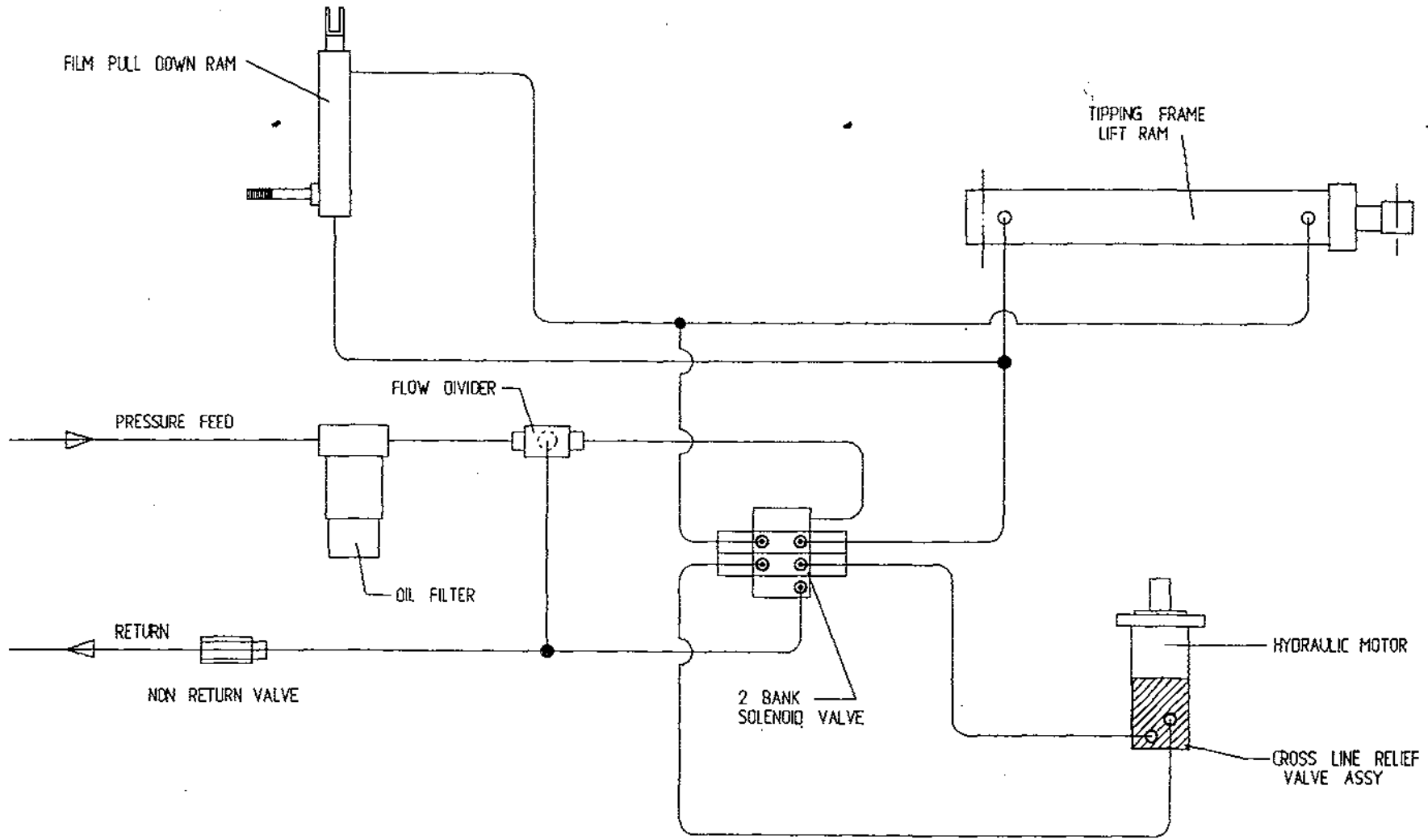

TANCO AUTOWRAP 250 ARC MODEL 1996
HYDRAULIC COMPONENTS

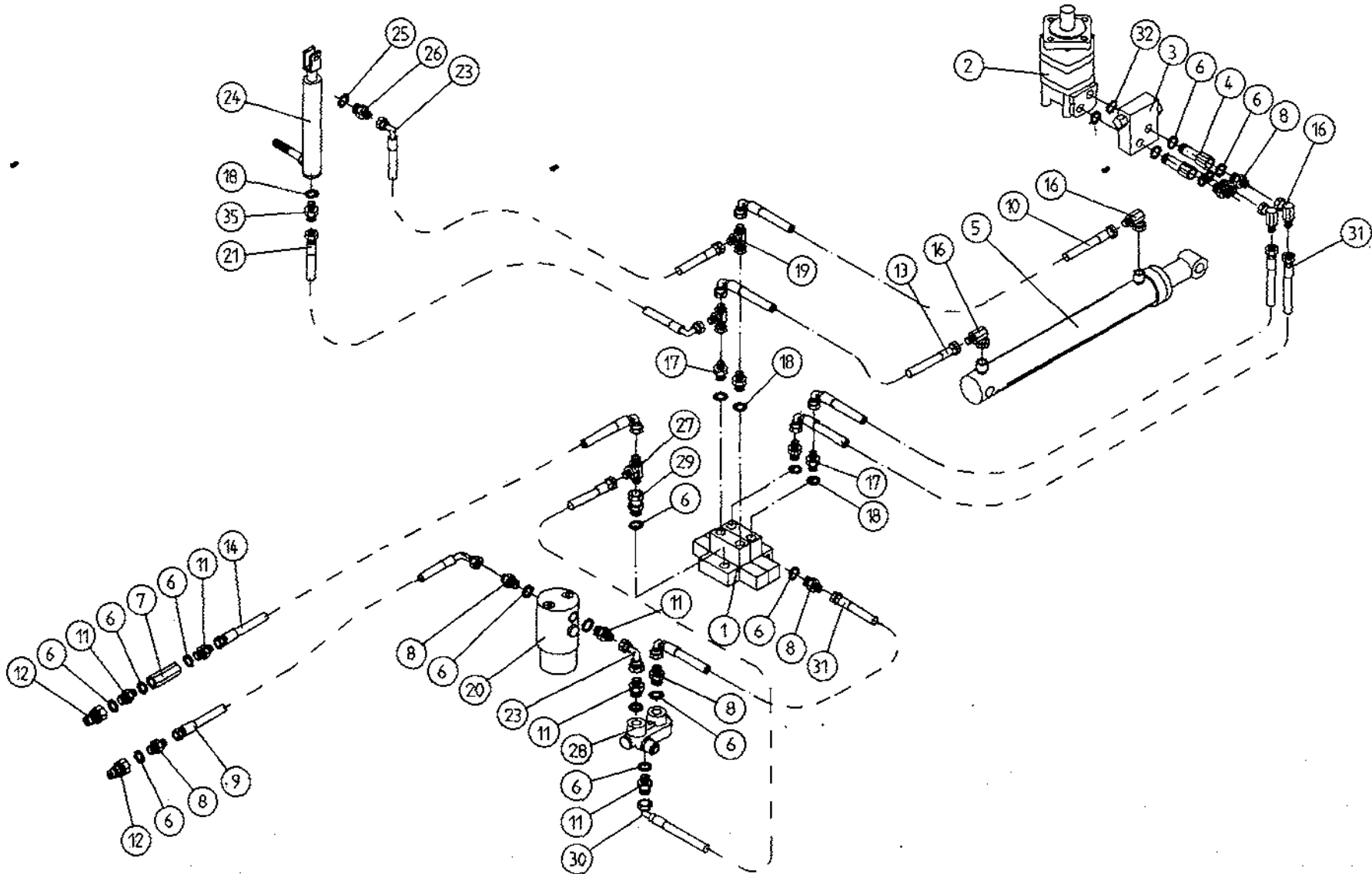

TANCO AUTOWRAP 250 ARC MODELS 1996
HYDRAULIC COMPONENTS

PARTS LIST

ITEM NO	DESCRIPTION	QTY.	PART-NO.
1.	2 BANK SPOOL SOLENOID VALVE	1	Z01-03-10-A2
2.	HYDRAULIC MOTOR (C.L.)	1	Z01-02-RF200
3.	CROSS LINE RELIEF VALVE	1	Z01-03-004
4.	1/2" B.S.P. BOTTOM BANJO BOLT (SPECIAL)	2	Z01-18-081
5.	HYD. RAM (TIPPING FRAME)	1	Z01-01-AR687
6.	1/2" DOWTY WASHER	19	Z01-04-03
7.	1/2" NON RETURN VALVE	1	Z01-03-017
8.	1/2" x 3/8" ADAPTOR	9	Z01-06-06-08
9.	72" ST/90 3/8" D/W HOSE	1	Z38-R2-72-S9
10.	48" ST/90 3/8" D/W HOSE	1	Z38-R2-48-S9
11.	1/2" x 1/2" ADAPTOR	3	Z01-06-08-08
12.	1/2" MALE END Q/R COUPLING	2	Z01-15-081
13.	36" ST/90 3/8" D/W HOSE	1	Z38-R2-36-S9
14.	96" ST/90 1/2" D/W HOSE	1	Z12-R1-96-S9
15.	30" ST/90 3/8" D/W HOSE	1	Z38-R2-30-S9
16.	3/8" MALE/FEMALE 90 ELBOW	4	Z01-14-015
17.	3/8" x 3/8" ADAPTOR	5	Z01-06-06-06
18.	3/8" DOWTY WASHER	5	Z01-04-02
19.	3/8" MALE x 3/8" MALE x 3/8" FEMALE 'T' PIECE	2	Z01-12-002
20.	FILTER	1	Z01-24-08
21.	84" ST/90 3/8" D/W HOSE	1	Z38-R2-84-S9
22.	3/8" X 3/8" ADAPTOR FITTED WITH 0.06" RESTRICTOR	1	Z01-03-40
23.	96" ST/90 3/8" D/W HOSE	1	Z38-R2-96-S9
24.	HYD RAM D/A (PULL DOWN ARM)	1	Z01-01-AW25
25.	1/4" DOWTY WASHER	1	Z01-04-01
26.	1/4" x 3/8" ADAPTOR	1	Z01-06-04-06
27.	1/2" MALE "T" PIECE	1	Z01-11-003
28.	INLINE FLOW DIVIDER	1	Z01-03-10-A7
29.	1/2" MALE x 1/2" FEMALE ADAPTOR	1	Z01-05-08-08
30.	20" ST/90 1/2" D/W HOSE	1	Z12-R2-19-S9
31.	108" ST/90 3/8" D/W HOSE	2	Z38-R2-608-S9
32.	COPPER WASHER	2	Z01-04-15

INSTRUCTIONS FOR FITTING TWO WAY SOLENOID VALVE TO TANCO AUTOWRAP MODELS 250 ARC,

REQUIRE WHEN OPERATING MACHINES ON TRACTORS WITH CLOSED CENTRE HYDRAULIC SYSTEMS.

1. Disconnect S/90 hose from inlet port on oil filter.
2. Connect port "T" on solenoid valve assembly to inlet port on oil filter.
3. Reconnect St/90 hose to port "P" on solenoid valve.
4. Connect 2 pin female connector to existing 2 pin connector at junction box.
5. Ensure valve assembly does not foul any rotating parts.
6. Change the seventh controller function setting from n to j
See instruction manual for further information.

**TANCO AUTOWRAP 250 ARC MODEL (1996)
TWO WAY SOLENOID VALVE KIT PART NO. Z01-03-018A**

PARTS LIST			
ITEM NO	DESCRIPTION	QTY	PART NO.
1	TWO WAY SOLENOID VALVE	1	Z01-03-10-A9
2	1/2" DOWTY WASHER	2	Z01-04-03
3	3/8" FEMALE x 1/2" MALE ADAPTOR	1	Z01-05-06-08
4	3/8" MALE/FEMALE 90 ELBOW	1	Z01-14-015
5	1/2" x 3/8" ADAPTOR	1	Z01-06-06-08

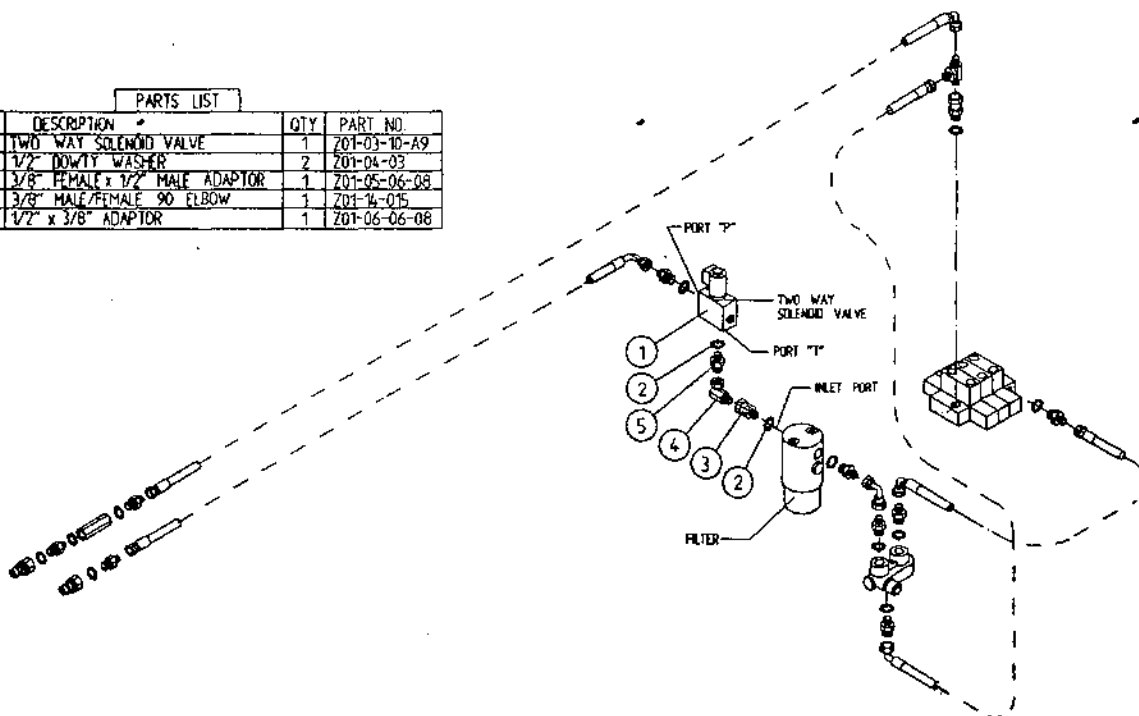

FILE NAME 9228L

TANCO AUTOWRAP 1996 MODEL

CONSTANT INDEXING DRIVE ASSY

NOTE:
ITEMS MARKED WITH * DENOTES ITEMS
REQUIRED FOR AUTOMATIC MODELS ONLY

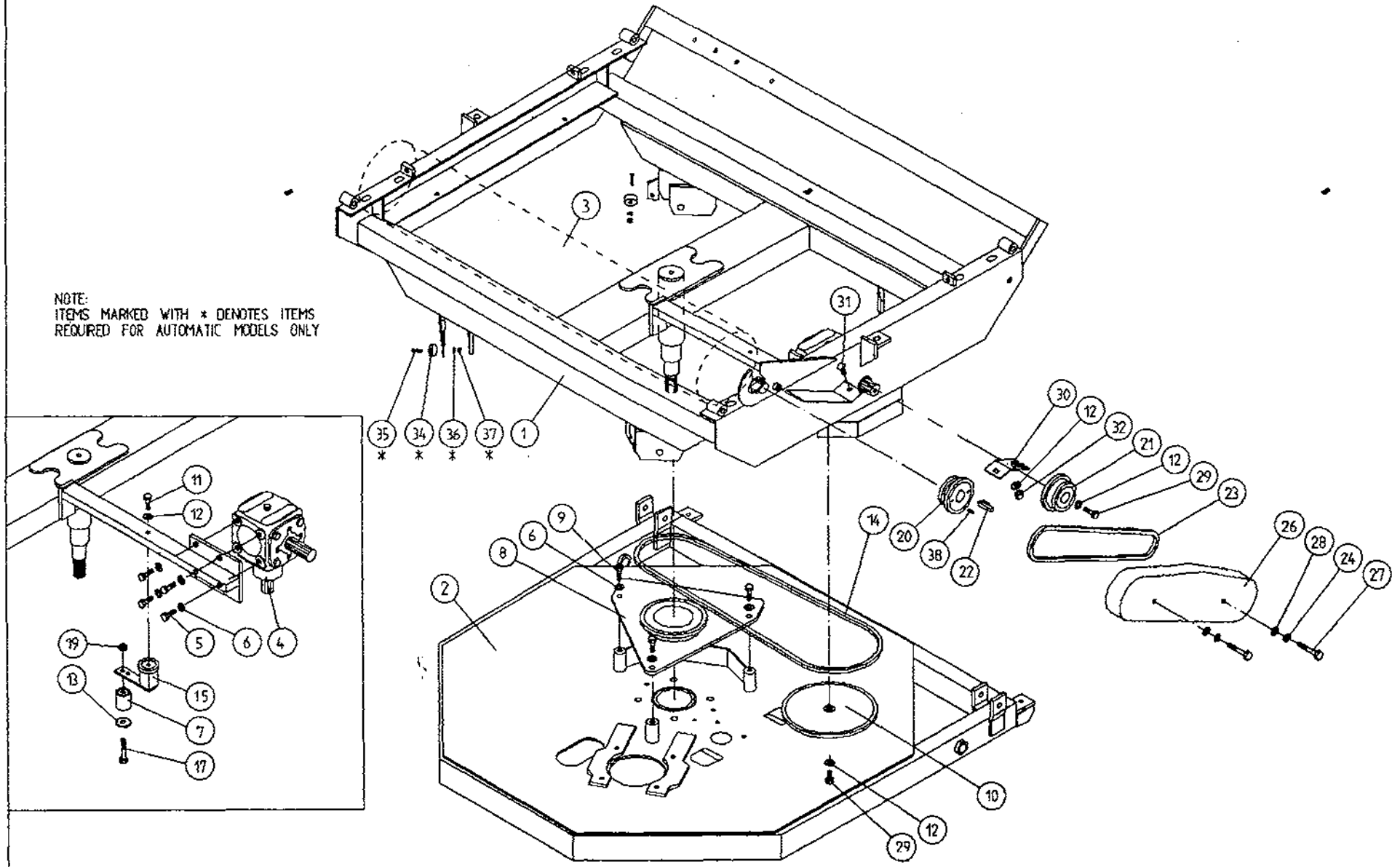

FILE NAME WD66 - PL6

TANCO AUTOWRAP
CONSTANT INDEXING DRIVE ASSEMBLY 1996

PARTS LIST

ITEM NO.	DESCRIPTION	QTY.	PART-NO
1	TURNTABLE ASSY.	1	WD66-TA
2	TIPPING FRAME ASSY.	1	WD64-TF
3	DRIVE ROLLER ASSY.	1	WD66-BRD
4	GEAR BOX	1	Z01-25-300
5	M12 HEX HD SET x 30mm LONG	4	Z26-082S
6	12mm DIA SPRING WASHER	7	Z12-02-12
7	CHAIN TENSIONER	1	WD60-CT
8	CENTRE SPROCKET ASSY 27 TOOTH	1	WD64-CSA
9	M12 HEX HD SET x 25mm LONG	3	Z26-081S
10	46 TOOTH SPROCKET	1	Z06-D64-46S
11	M10 HEX HD SET x 25mm LONG	1	Z26-0611S
12	10mm DIA SPRING WASHER	4	Z12-02-10
13	RETAINING COLLAR	1	WD623-071
14	CHAIN 3/4" PITCH X 87 PITCHES	1	Z09-AW-5
15	ROSTA TENSIONING UNIT ARM	1	Z06-454
17	M10 HEX HD BOLT x 65mm LONG	1	Z26-0671B
19	M10 LOCKNUT	1	Z23-10
20	SPROCKET DOUBLE SIMPLEX 13T/16T KEYED	1	Z06-D64-1316K
21	SPROCKET DOUBLE SIMPLEX 13T/16T SPLINED	1	Z06-D65-1316S
22	KEY 5/16" x 5/16" x 32mm LONG	1	WD623-K32
23	CHAIN 3/4" PITCH X 62 PITCHES	1	Z09-AW-3
24	1/2" DIA STAR WASHER	2	Z10-01-121
26	CHAIN GUARD	1	WD60-CGC
27	M10 HEX HD SET x 70mm LONG	2	Z26-068B
28	10mm DIA FLAT WASHER	2	Z10-02-10
29	M10 HEX HD SET x 30mm LONG	2	Z26-062S
30	CHAIN STRIPPER	1	WD66-053
31	M10 CUP SQ. SCREW x 30mm LONG	1	Z13-112
32	M10 HEX NUT	1	Z18-10
34*	MAGNET	2	D6043
35*	M6 CSK HD SET x 35mm LONG	2	Z13-132
36*	6mm DIA FLAT WASHER	2	Z11-02-06
37*	M6 LOCKNUT	2	Z23-06
38	SPIRAL PIN	2	Z03-23-062

* DENOTE ADDITIONAL ITEMS REQUIRED FOR AUTOMATIC MACHINES

TANCO AUTOWRAP 250 ARC MODEL 1996

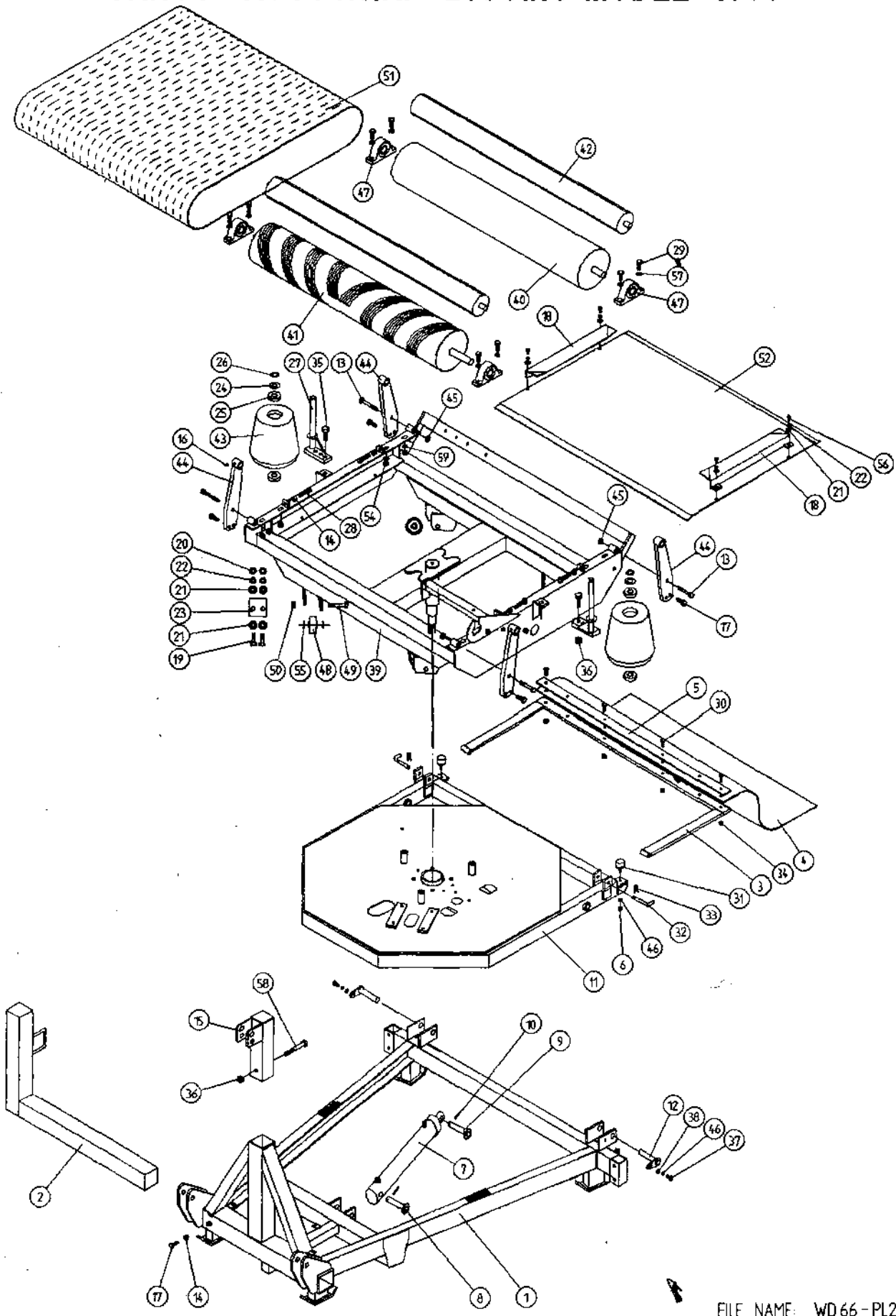

FILE NAME: WD 66 - PL20

WD66-PL20
TANCO AUTOWRAP 250ARC MODEL (3 PT. LINKAGE) 1996
PARTS LIST

ITEM	DESCRIPTION	QTY	PART-NO.
1.	3 PT. LINKAGE FRAME ASSEMBLY	1	WD63-MF
2.	DISPENSER BRACKET LOWER SUPPORT	1	ZWD63-DMLH
3.	RUBBER MAT MOUNTING FRAME ASSEMBLY	1	WD63-MMF
4.	RUBBER MAT	1	Z05-02AM
5.	CLAMPING PLATE	1	WD63-1300
6.	M10 HEX NUT	2	Z18-10
7.	HYD. RAM	1	Z01-01-AR687
8.	RAM. BOTTOM PIVOT PIN	1	Z03-02-330
9.	RAM TOP PIVOT PIN	1	Z03-03-50
10.	2" X 1/4" SPLIT PIN	2	Z03-21-29
11.	TIPPING FRAME ASSY	1	WD64-TF
12.	TIPPING FRAME PIVOT PIN C/W GREASE NIPPLE	2	Z03-01-905 Z39-60
13.	M12 HEX HD BOLT X 80MM LONG	4	Z26-0901B
14.	M12 HEX NUT	5	Z16-12
15.	TOP LINK BRACKET ASSEMBLY	1	WD63-TLB
16.	1/8" B.S.P. ST GREASE NIPPLE	4	Z39-60
17.	M12 HEX HD SET x 40mm LONG	5	Z26-084S
18.	BELT GUIDE ASSY	2	WD66-BG
19.	M8 HEX HD SETS X 20MM LONG	4	Z26-039S
20.	M8 HEX NUTS	14	Z18-08
21.	8MM DIA FLAT WASHERS (MUD FLAP)	8	Z11-02-081
22.	8MM DIA SPRING WASHERS	12	Z12-02-08
23.	SCRAPER	2	WD60-711
24.	THRUST WASHER	2	WD60-292
25.	BEARING (25MM I.D.)	4	Z06-AWRB-93
26.	CIRCLIP	2	Z28-525
27.	END ROLLER MOUNTING BRACKET	2	WD66-ERH
28.	M12 HEX HD SET X 60MM LONG	4	Z26-088S
29.	M14 HEX HD SET X 55MM LONG	8	Z26-105S
30.	M8 HEX HD BOLT x 50mm LONG	4	Z26-045B
31.	BUFFER 56mm DIA x 40mm LONG	2	Z40-20
32.	BISSEL PIN	2	Z03-22-AW100
33.	4MM "R" CLIP	2	Z36-02
34.	M8 LOCKNUTS	4	Z23-08
35.	M16 HEX HD SET X 50MM LONG	6	ZZG-124S
36.	M16 LOCKNUTS	3	Z23-16
37.	M10 HEX HD SET x 25mm LONG (TUFLOCK)	2	Z26-061S
38.	10 mm DIA MACHINED FLAT WASHER	2	Z11-02-10
39.	TURN TABLE ASSY	1	WD66-TA
40.	BELT ROLLER ASSY IDLER	1	WD66-BRI
41.	BELT ROLLER ASSY DRIVER	1	WD66-BRD
42.	SMALL ROLLER ASSY	2	WD66-SMR
43.	SIDE ROLLER	2	Z06-AWR
44.	ROLLER MTG BRACKET	4	WD66-RMB
45.	M12 LOCKNUTS	8	Z23-12
46.	10mm DIA SPRING WASHER	6	Z12-02-10
47.	1 1/4" PILLOW BLOCK BEARING C/W CAM LOCK COLLAR	4	Z06-485
48.	SUPPORT WHEELS (4" DIA)	4	Z06-466
49.	AXLE ASSY C/W GREASE NIPPLE	4	Z03-22-AW/AX Z39-60
50.	M20 LOCKNUTS	4	Z23-20
51.	1200MM WIDE X 2475MM LONG X 1/4" FLAT BELT	1	Z05-02AW96
52.	TURN TABLE COVER PLATE	1	WD66-043
54.	M14 HEX NUT	4	Z18-14
55.	SPACER	8	WD60-198
56.	M8 HEX HD SET X 30MM LONG	4	Z26-041S
57.	14MM DIA FLAT WASHER	8	Z11-02-14
58.	M16 HEX HD BOLT x 120mm LONG	1	Z26-134B
59.	14mm DIA SPRING WASHER	4	Z12-02-14

TANCO AUTOWRAP 1996 MODEL TURNTABLE CHAIN DRIVE ASSEMBLY

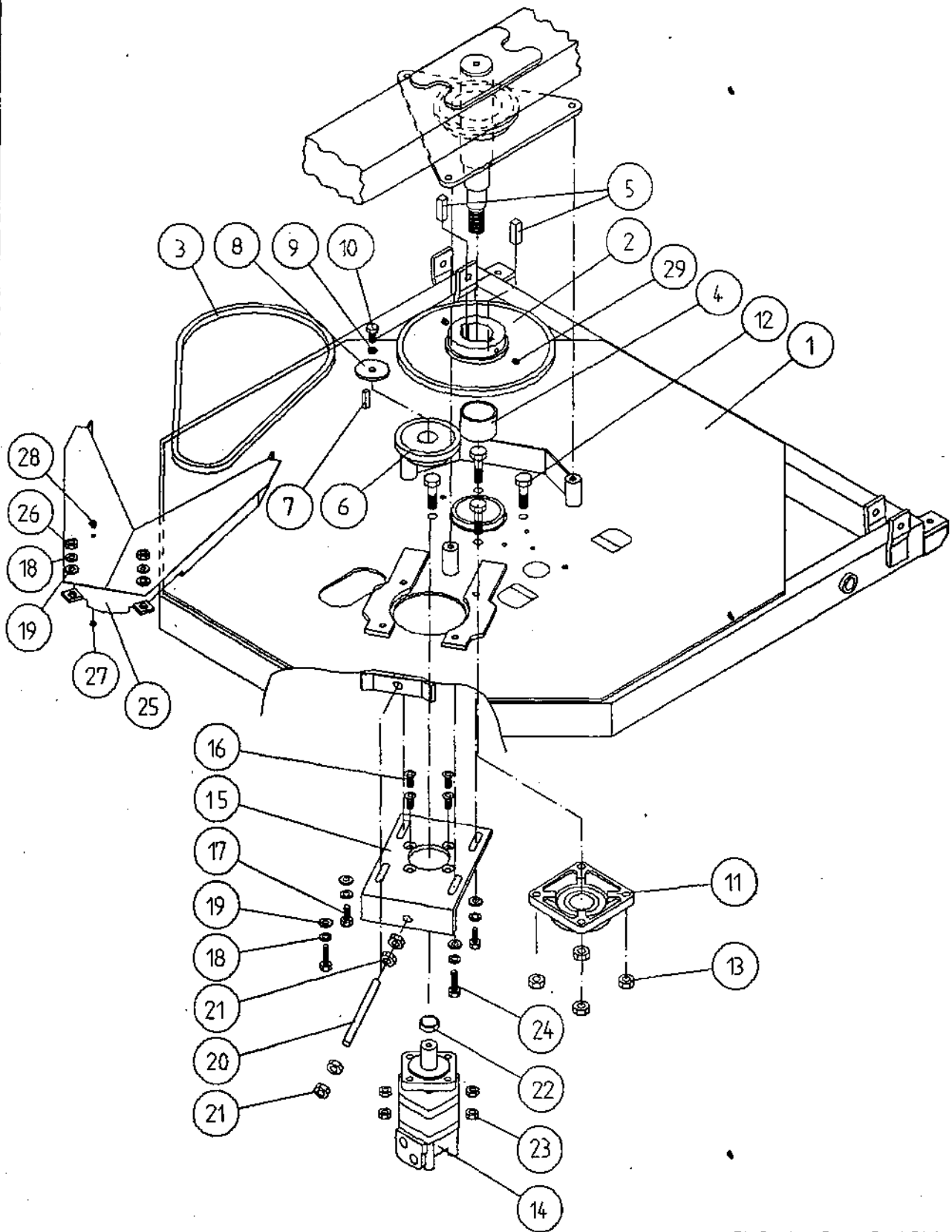

FILE NAME: WD66 PL9

WD66-PL9

TANCO AUTOWRAP 1996 MODEL
TURNTABLE CHAIN DRIVE ASSEMBLY

PARTS LIST

ITEM NO	DESCRIPTION	QTY	PART NO
1	TIPPING FRAME ASSY	1	WD64-TF
2	38 TOOTH x 1" PITCH SPROCKET	1	Z06-D64-38
3	CHAIN 1" PITCH x 54 PITCHES	1	Z09-AW6
4	SPINDLE SPACER	1	WD64-040
5	KEY 5/8" SQ x 50mm LONG	2	WD64-052
6	15 TOOTH x 1" PITCH SPROCKET	1	Z06-I60-046
7	KEY 5/16" SQ x 45mm LONG	1	WD64-053
8	LOCKING COLLAR	1	WD623-071
9	10mm DIA SPRING WASHER	1	Z12-02-10
10	3/8" UNC HEX HD SET x 1" LONG	1	Z27-023S
11	2" DIA FLANGE BEARING C/W CAM LOCK COLLAR	1	Z06-49EC
12	5/8" UNF HEX HD SET x 2" LONG	4	Z31B-064
13	5/8" UNF LOCKNUT	4	Z20-10
14	HYDRAULIC MOTOR	1	Z01-02-RF200
15	HYDRAULIC MOTOR MOUNTING PLATE	1	WD64-001
16	M12 x 50mm ALLEN HD C/S SCREW	4	Z13-5-12X50
17	M12 HEX HD SET x 30mm LONG	4	Z26-082S
18	12mm DIA SPRING WASHER	6	Z12-02-12
19	12mm DIA FLAT WASHER	6	Z10-02-12
20	M16 THREADED BAR x 150mm LONG	1	WD64-038
21	M16 HEX NUTS	4	Z18-16
22	SPACER	1	WI60-093
23	M12 LOCKNUTS	4	Z23-12
24	M12 HEX HD SET x 50mm LONG	2	Z26-086S
25	DRIVE CHAIN GUARD	1	WD66-DCG
26	M12 HEX NUT	2	Z18-12
27	M6 HEX NUT	1	Z18-06
28	M6 90 DEGREE GREASE NIPPLE	1	Z39-65
29	M12 GRUB SCREW x 16mm LONG	2	Z28-012

TANCO AUTOWRAP 250 ARC MODEL 1996SOLENOID VALVE & JUNCTION BOX ASSYPARTS LIST

ITEM NO.	DESCRIPTION	QTY.	PART-NO.
1.	FILM MAST ASSEMBLY	1	
2.	ROTATING BEACON	1	Z05-18
3.	STEM C/W CABLE	1	Z05-181
4.	M8 x 10mm GRUB SCREW	1	Z28-008
5.	BEACON MOUNTING BRACKET	1	WD63-BMB
6.	RECEIVER	1	D6071
7.	RUBBER BUFFER	2	Z40-27
8.	M6 LOCKNUT	4	Z23-06
9.	M12 HEX HD BOLT x 30mm	2	Z26-082S
10.	12mm DIA FLAT WASHER	2	Z10-02-12
11.	12mm DIA SPRING WASHER	2	Z12-02-12
12.	SOLENOID VALVE MOUNTING PLATE	1	WD63-1027
13.	JUNCTION BOX MOUNTING BRACKET	1	WD63-JMB
14.	JUNCTION BOX	1	ZDC-JB2
15.	M4 ALLEN HD SOCKET SCREW x 16mm	4	Z26-006
16.	M4 LOCKNUT	4	Z23-04
17.	M10 HEX HD SET x 25mm	2	Z26-0611S
18.	10mm DIA FLAT WASHER	2	Z10-02-10
19.	M8 LOCKNUT	8	Z23-08
20.	2 BANK SOLENOID VALVE	1	Z01-03-10-A2
21.	VALVE & JUNCTION BOX COVER	1	WD63-UC
22.	OIL FILTER	1	Z01-24-08
22A.	OIL FILTER ELEMENT	1	Z01-24-08E
23.	FILTER MOUNTING BRACKET	1	WD63-1053
24.	M8 HEX HD SET x 25mm	8	Z26-040S
25.	8mm DIA FLAT WASHER	2	Z10-02-08
26.	8mm DIA SPRING WASHER	2	Z12-02-08
27.	3PT LINKAGE FRAME	1	WD610-LF
28.	STABILISING LEG ASSY	2	WD63-SLA
29.	M12 HEX HD BOLT x 80mm	2	Z26-0901B
30.	M12 LOCKNUTS	2	Z23-12
31.	10mm DIA SPRING WASHER	2	Z12-02-10
32.	FLOW DIVIDER	1	Z01-03-10-A6
33.	FLOW DIVIDER MOUNTING BRACKET	1	WD65-FDM
34.	M6 ALLEN HD SOCKET SCREW 50MM	2	Z13-020-50
35.	6MM DIA MUD FLAP WASHER	2	Z11-02-061
36.	M6 LOCKNUT (NYLOCK)	2	Z23-06
37.	M8 HEX HD BOLT X 65MM LONG	2	Z26-048B
38.	PACKER (JUNCTION BOX)	1	WD612-034

TANCO AUTOWRAP 250 ARC MODEL 1996 SOLENOID VALVE & JUNCTION BOX ASSY

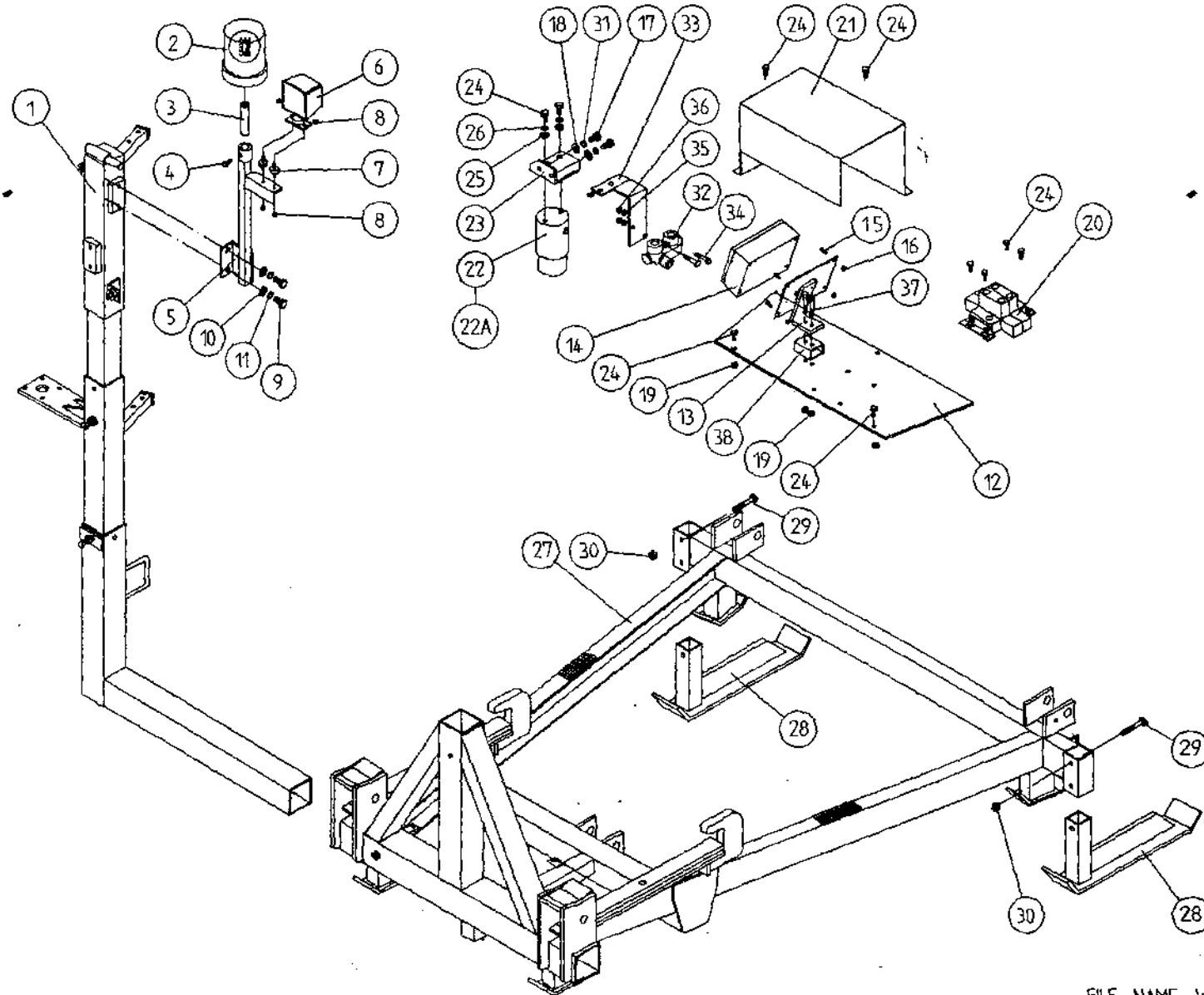

FILE NAME WD 64-PL51

TANCO AUTOWRAP 250 ARC MODEL 1996 FILM DISPENSOR SYSTEM

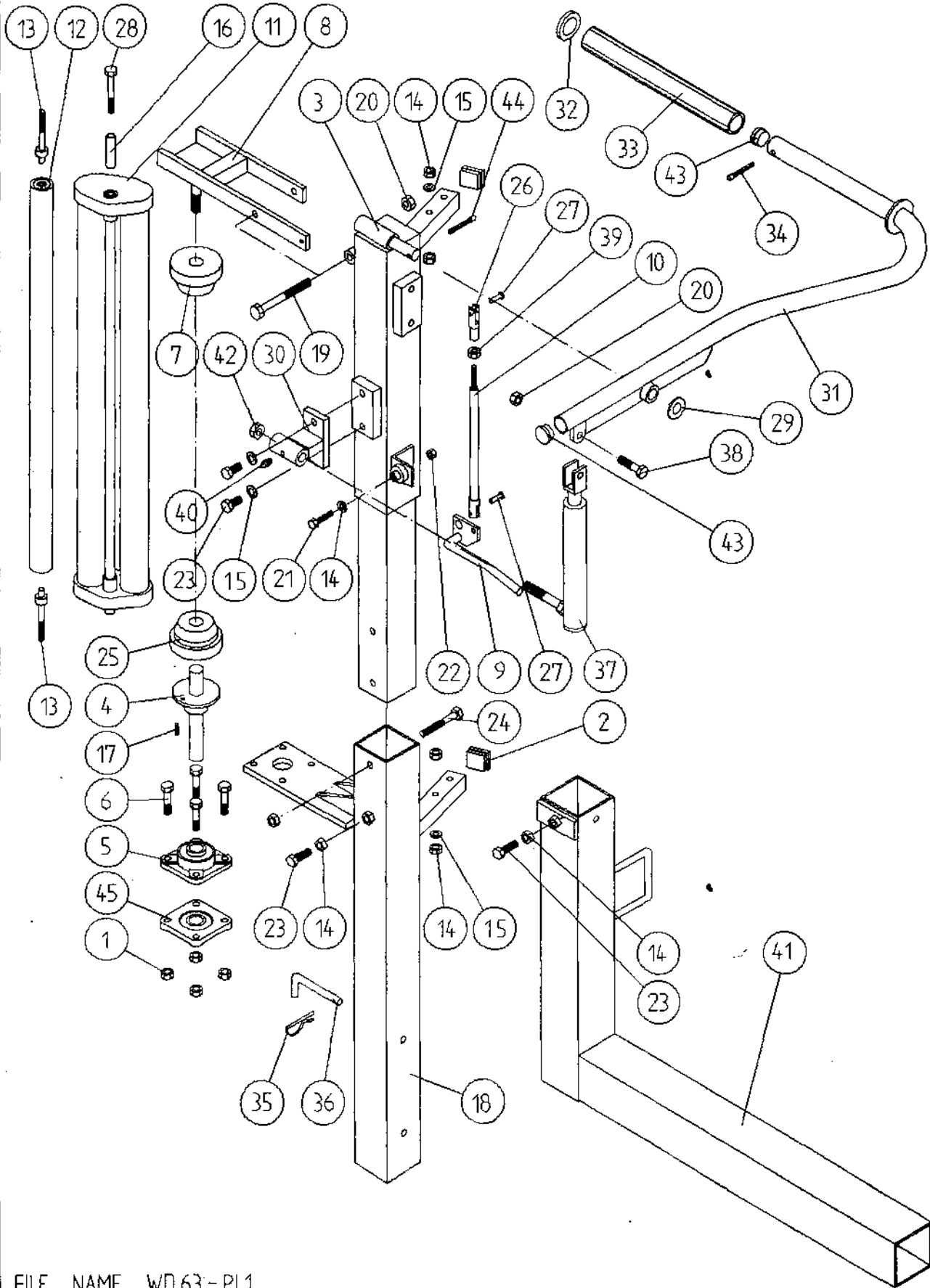

FILE NAME WD63-PL1

TANCO AUTOWRAP 250 ARC MODEL 1996
FILM DISPENSING SYSTEM

PARTS LIST

ITEM NO.	DESCRIPTION	QTY.	PART-NO.
1.	M10 LOCKNUTS	4	Z23-10
2.	(PLASTIC CAPS TO SUIT 40 x 40 x 3 x RHS)	2	Z32-07
3.	DISPENSER MOUNTING (UPPER)	1	WD60-DMUH
4.	FILM SPOOL ASSEMBLY	1	WD60-SPO
5.	1" DIA FLANGE BEARING C/W CAM LOCK	1	Z06-48EC
6.	M10 HEX HD BOLT X 50mm LONG	4	Z26-066B
7.	CONE (TOP) C/W BALL BEARINGS	1	Z06-45-01
8.	CLAMP ASSEMBLY	1	WD60-DMCA
9.	LEVER ASSEMBLY	1	WD60-DMLA
10.	LINK ASSEMBLY	1	WD60-DMLK
11.	FILM DISPENSER UNIT MK 9 (70% STRETCH)	1	D616
12.	SLAVE ROLLER ASSY (LONG)	1	Z06-SR95-L
13.	SLAVE ROLLER PIVOT	2	WD64-SRP
14.	M12 HEX NUTS	7	Z18-12
15.	12mm DIA SPRING WASHER	2	Z12-02-12
16.	SLEEVE	1	D52012-95
17.	1/4" DIA TENSION PIN x 3/4" LONG	1	Z03-20-062
18.	DISPENSER MOUNTING (LOWER)	1	WD60-DMLH
19.	M12 HEX HD BOLT x 130mm LONG	1	Z26-094B
20.	M12 LOCKNUT	3	Z23-12
21.	M8 HEX HD BOLT x 35mm LONG	1	Z26-042S
22.	M8 LOCKNUT	1	Z23-08
23.	M12 HEX HD SET x 30mm LONG	3	Z26-082S
24.	M12 HEX HD BOLT x 100mm LONG	1	Z26-092B
25.	CONE (BOTTOM)	1	Z06-45-02
26.	CLEVIS (M10)	1	Z49-335
27.	PIN (5/16" DIA) C/W CLIP	2	Z49-337
28.	M12 HEX HD BOLT x 80mm LONG	1	Z26-0901B
29.	3/4" DIA FLAT WASHER	1	Z10-02-19
30.	FILM PULL DOWN BRACKET ASSY	1	WD65-FPDB
31.	FILM PULL DOWN ARM ASSY	1	WD65-FPDA
32.	RETAINING WASHER	1	WD60-859
33.	ROLLER	1	WD60-866
34.	2" x 1/4" SPLIT PIN	1	Z03-21-29
35.	4mm "R" CLIP	1	Z36-02
36.	BISSEL PIN (110mm LONG)	1	WD60-861
37.	HYDRAULIC RAM	1	Z01-01-AW25
38.	M12 HEX HD SET x 50mm LONG	1	Z26-086S
39.	5/16" UNF HEX NUT	1	Z15-05
40.	1/8" BSP ST GREASE NIPPLE	1	Z39-60
41.	DISPENSER BRACKET LOWER SUPPORT	1	WD63-DMLH
42.	M16 LOCKNUT	1	Z23-16
43.	1" GB PLASTIC CAP	2	Z32-14
44.	1/2" x 3/16" SPLIT PIN	1	Z03-20-05
45.	1" DIA FLANGE BEARING	1	Z06-48

TANCO AUTOWRAP CUT AND START UNIT (1996)

MAIN ASSEMBLY

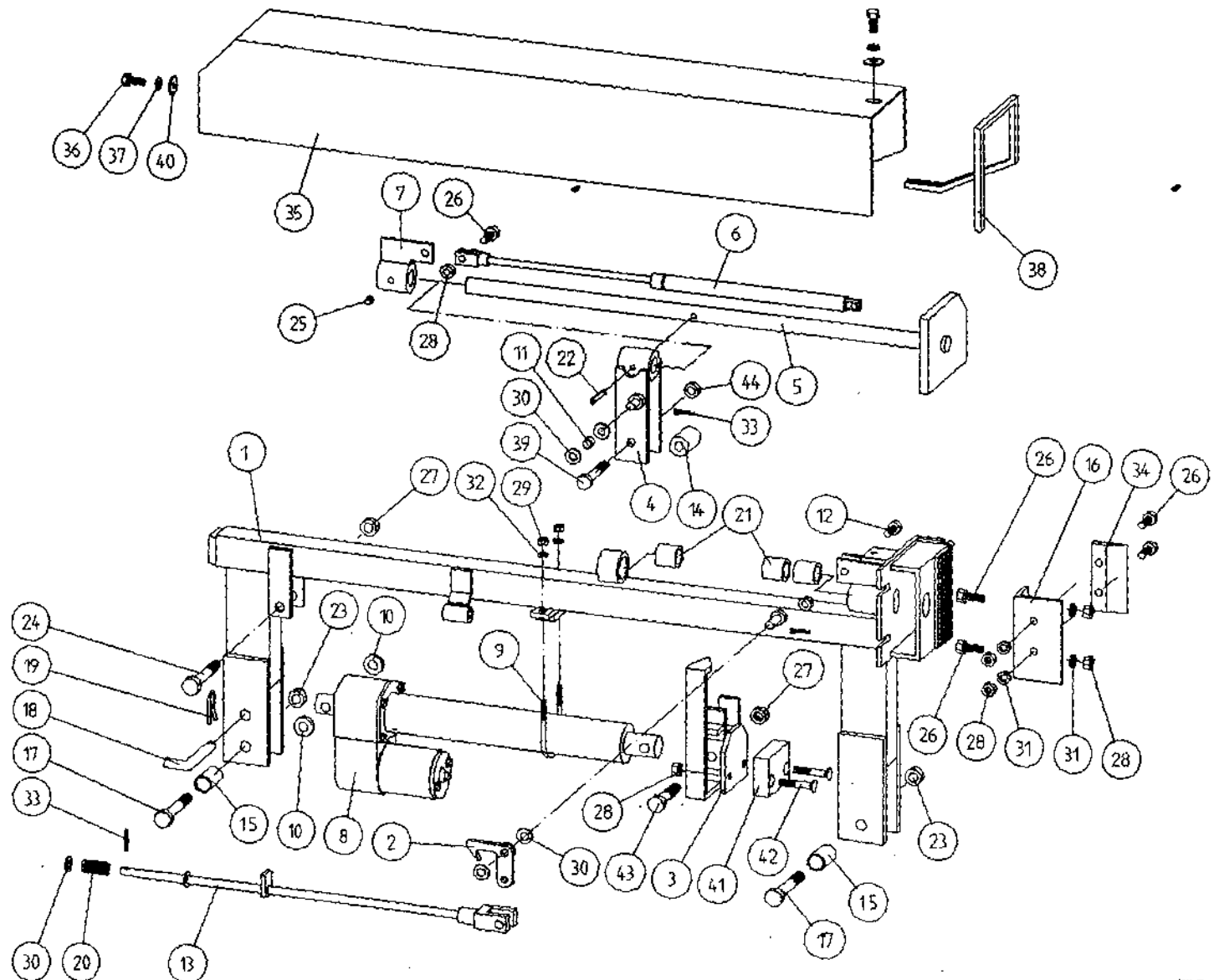

29

**TANCO AUTOWRAP
CUT AND START UNIT (1996)
PARTS LIST**

ITEM NO	DESCRIPTION	QTY	PART-NO.
1.	MAIN MOUNTING FRAME ASSY	1	WD605-MF1
2.	LATCH ASSY.	1	WD605-LA
3.	PUSH PLATE / POINTER ASSY.	1	WD605-PPP
4.	GUIDE ASSY	1	WD605-GD1
5.	PLUNGER ASSY	1	WD605-PL1
6.	GAS SPRING	1	Z07-47
7.	GAS SPRING MOUNTING BRACKET	1	WD605-GSM
8.	WARNER LINEAR ACTUATOR D11 10B5 08	1	ZD605-510
9.	"U" BOLT	1	WD605-45
10.	SPACER 1" X OD X 1/2" ID X 6mm LONG	2	WD605-65
11.	SLEEVE 1/2" DIA O.D. X 13/32" DIA I.D.	1	WD605-47
12.	M8 HEX HD SET X 35mm LONG	1	Z26-042S
13.	TRIGGER ASSEMBLY	1	WD605-TRG
14.	COLLAR 1" DIA BRIGHT RD. X 41.5mm LONG	1	WD605-51
15.	SPACER	1	WD605-100
16.	BLADE GUARD/MOUNTING BRACKET	1	WD605-105
17.	M12 HEX HD BOLT X 80mm LONG	2	Z26-0901B
18.	BISSEL PIN	1	Z03-22-AW100
19.	4mm "R" CLIP	1	Z36-02
20.	SPRING 16mm O.D X 1.5mm WIRE X 48mm LONG	1	Z07-34
21.	OILITE OIL RETAINING BUSH 1 1/8" O.D.	3	Z06-105
22.	1 1/2" X 1/4" DIA TENSION PIN	1	Z03-20-07
23.	M12 LOCKNUTS	2	Z23-12
24.	M12 HEX HD BOLT X 65mm	1	Z26-0882B
25.	M8 GRUB SCREW	1	Z28-008
26.	M8 HEX HD SET X 25mm	3	Z26-040S
27.	M12 BINX LOCKNUT	4	Z23-12BX
28.	M8 LOCKNUT	8	Z18-08
29.	M6 LOCKNUT (NYLOCK)	2	Z23-06
30.	10mm DIA FLAT WASHER	10	Z11-02-10
31.	8mm DIA FLAT WASHER	5	Z11-02-08
32.	6mm DIA FLAT WASHER	2	Z11-02-06
33.	3mm DIA SPLIT PIN	2	Z03-21-02
34.	BLADE	1	WD605-104
35.	MAIN GUARD	1	WD605-MG
36.	M8 HEX HD SET X 20mm LONG	2	Z26-039S
37.	8mm DIA SPRING WASHER	9	Z12-02-08
38.	EDGING STRIP	1	Z44-12
39.	M10 HEX HD SET X 20mm	2	Z26-060S
40.	8mm DIA FLAT WASHER 1" O.D.	4	Z11-02-081
41.	PACKER	1	WD605-133
42.	M8 X 40 COUNTER SUNK BOLT	2	Z13-5-08X40
43.	M12 HEX HD BOLT X 50mm LONG	1	Z26-086B
44.	M10 LOCKNUT	1	Z23-10

TANCO AUTOWRAP - CUT AND START UNIT (1996) SLIP RING ASSEMBLY

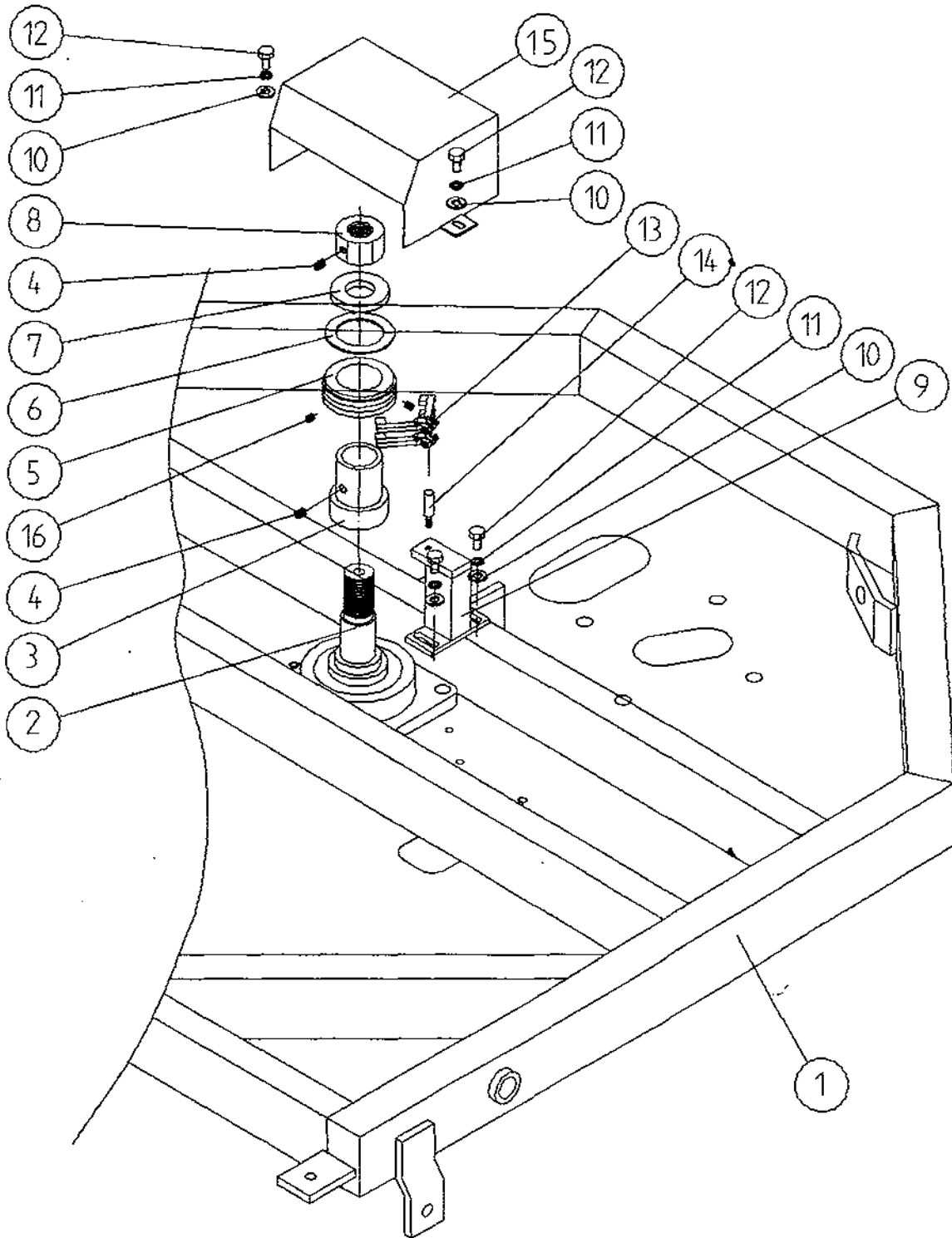

FILE NAME: WO 64 - PL20

WD64-PL20

TANCO AUTOWRAP CUT AND START UNIT (1996)
SLIP RING ASSY.

PARTS LIST

<u>ITEM NO.</u>	<u>DESCRIPTION</u>	<u>QTY.</u>	<u>PART-NO.</u>
1.	UNDERSIDE OF TIPPING FRAME	1	WD64-TF
2.	TURNTABLE CENTRE SHAFT	1	WD64-002
3.	SLIP RING MOUNTING SLEEVE	1	WD605-161
4.	M8 GRUB SCREW x 6 mm LONG	2	Z28-007
5.	SLIP RING ASSY.	1	ZD605-308
6.	INSULATING RING	1	ZD605-350
7.	LOCKING COLLAR	1	WD60-770
8.	1 1/4" UNC HEX NUT	1	Z18-300
9.	SLIP RING MOUNTING BRACKET ASSY	1	WD605-BMB
10.	10mm DIA FLAT WASHER 1" O.D.	4	Z11-02-101
11.	10mm SPRING WASHER	4	Z12-02-10
12.	M10 HEX HD SET x 20mm	4	Z26-060S
13.	BRUSHES	2	ZD605-306
14.	INSULATOR SLEEVE	1	ZD605-302
15.	SLIP RING GUARD ASSY	1	WD605-SRG
16.	M5 GRUB SCREW	2	Z28-005

TANCO AUTOWRAP CUT AND START UNIT (1996)
SENSOR & MAGNET MOUNTING BRACKETS

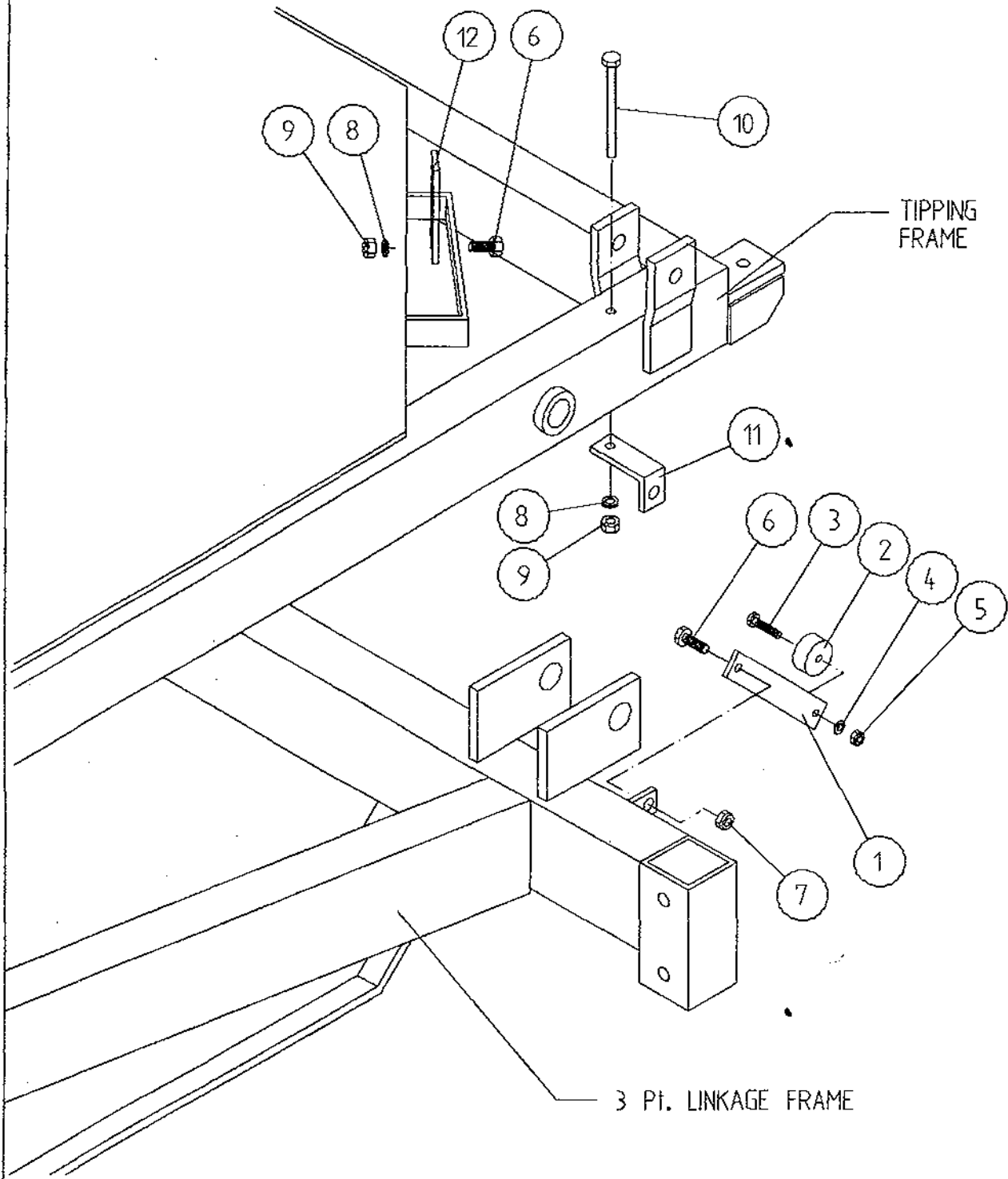

FILE NAME WD64 - PL52

TANCO AUTOWRAP CUT AND START UNIT 1996SENSOR AND MAGNET MOUNTING BRACKETSPARTS LIST

<u>ITEM NO.</u>	<u>DESCRIPTION</u>	<u>QTY.</u>	<u>PART-NO.</u>
1.	MAGNET MOUNTING BRACKET	1	WD605-165
2.	MAGNET	1	D6043
3.	M6 HEX HD SET x 30mm LONG	1	Z26-022S
4.	6mm DIA FLAT WASHER	1	Z11-02-06
5.	M6 LOCKNUT	1	Z23-06
6.	M8 HEX HD SET x 25mm LONG	2	Z26-040S
7.	M8 LOCKNUT (NYLOCK)	1	Z23-08
8.	8mm DIA SPRING WASHER	2	Z12-02-08
9.	M8 HEX NUT	2	Z18-08
10.	M8 HEX HD SET x 100mm LONG	1	Z26-057S
11.	SENSOR MOUNTING BRACKET	1	WD605-58
12.	SENSOR MOUNTING FLAT	1	WD605-164

TANCO AUTOWRAP AUTOMATIC MODELS

Cut and start

Fault Finding Summary.

This summary is to be read in conjunction with operators handbook.

Note: It has been found that most faults can be attributed to a bad power supply. Therefore it is essential that power supply be taken directly from battery terminals, ensuring correct polarity.

Operating voltage is 10V D.C. (under load) to 13.5V D.C.

Problem

(1) Bale Wrap monitor does not power on.

(2) Plunger does not come out after 2 revolutions of turntable.

(2) (i) Buzzer sound continuously "bleep" bleep" and bale wrap monitor does not count above 2 revs.

(3) Plunger snaps closed after about 7 to 8 turntable revolutions. This is caused by the Linear Actuator not stopping in park position.

(4) When machine is tipped plunger does not close.

Proposed Remedy

(a) Check polarity on connections to battery terminals.

(b) Check fuse, in power supply cable to controller.

(a) Check operation in manual mode to ensure that plunger travels in and out. If the plunger does not travel in and out, check all connections from six pin plug, through slip ring to linear actuator.

(b) Check fuse in power supply cable to junction box and replace if necessary.

(c) Check voltage while operating in manual mode. This voltage should be no lower than 10V D.C. (under load). Also check connections on battery terminals.

(d) Check that bale wrap monitor is counting revolutions and if not check that turntable sensor is within 6mm of magnet on turntable.

(e) Carry out continuity check of turntable sensor, by taking reading across 2 & 3 in six pin plug.

(a) Reduce setting for programme (1), which indicates the number of seconds required to reverse to park position. Setting can be altered in increments of 0.5 sec. In the park position there should be 5mm to 12mm clearance between cam on push plate assy and latch trigger.

(a) Check clearance between tip sensor on back of tipping frame and magnet of 5mm to 6mm.

(b) Check that tip sensor passes magnet, if not adjust magnet position.

FAULT FINDING

PROBLEMS.

REMEDY.

1. Drive Roller and Bale belt not driving
Check and replace shear Pins in sprocket on drive roller.
2. Film Breaking
Wash off dispenser and slave rollers. Change roll of film. Use recommended films only.
3. Film not wrapping evenly on bale.
Adjust film mast so centre of film roll is aligned with centre of bale .
4. Film Tearing on Ramp.
Check for sharp edges and remove.
5. Bale Skidding on Ramp.
Fit Hessian Bag or piece of carpet to Ramp.
6. Film Dispenser not Pre-Stretching Film.
Check that both Rollers turn when one is turned by hand. If not, fit new gears or replace unit.
7. Tyres coming off 4" platform Support Wheels.
Replace Wheels - Reduce speed below 30 r.p.m. - Do not grease path of wheels on platform. Check that bale does not get trapped between arms and turntable when being loaded.

If this happens lower arm and start again.

8. BALE BELT TRACKING ADJUSTMENT

- (i) Ensure vertical rollers (plastic) are in tight on the bale. Remember that the bale will reduce in size during wrapping and, on the round bales in particular, the corners will become rounded so that the bale will tend to move sideways due to centrifugal forces. Now, if the plastic rollers are too far apart, the bale will move against one of the plastic rollers causing the belt to move in the opposite direction. Always adjust the vertical plastic rollers so that they keep the bale central on the belt.
- (ii) Adjust bale stop on lift arm so that bale is loaded centrally onto platform.
- (iii) Check that bale belt is fitted so arrow points in direction of travel.
- (iv) Check that both 8" rollers underneath the bale belt are parallel to each other. Remember the golden rule - a belt will always move up a slope: So, if the belt continually moves to our side, adjust idler roller to a narrower setting on the opposite side to which the belt travels.
- (v) Check that gripface strips are securely fixed to the roller and have not moved out of alignment.
- (vi) Check that is the same measurement each side by running a string around the belt and measuring it. If one side is longer than the other replace the belt.

EC DECLARATION OF CONFORMITY

according to Directives 89/392/336/EEC
as amended

Manufacturer

TANCO ENGINEERING CO. LTD.
BAGENALSTOWN
CO. CARLOW
IRELAND

Certifies that the following product:

AUTOWRAP

MODEL 250-ARC

SERIAL No. D2000 - D3000

To which this declaration relates, corresponds to the essential requirements of
the Directive 89/392/336/EEC as amended.

To conform to these essential health and safety requirements, the provisions of the
following harmonized standards were particularly considered:

EN 292 - 1,2 , EN 294 , EN 1152 , prEN 703 , prEN 811 , prEN 1553 , prEN 982.

DATE 01-01-96

SIGNATURE Alfred A Cox
ALFRED A. COX, TECHNICAL DIRECTOR